

Metallgerätehaus/ Metal tool shed/ Abri de jardin métal

weka

Item No.: 70224140600, 70224140700

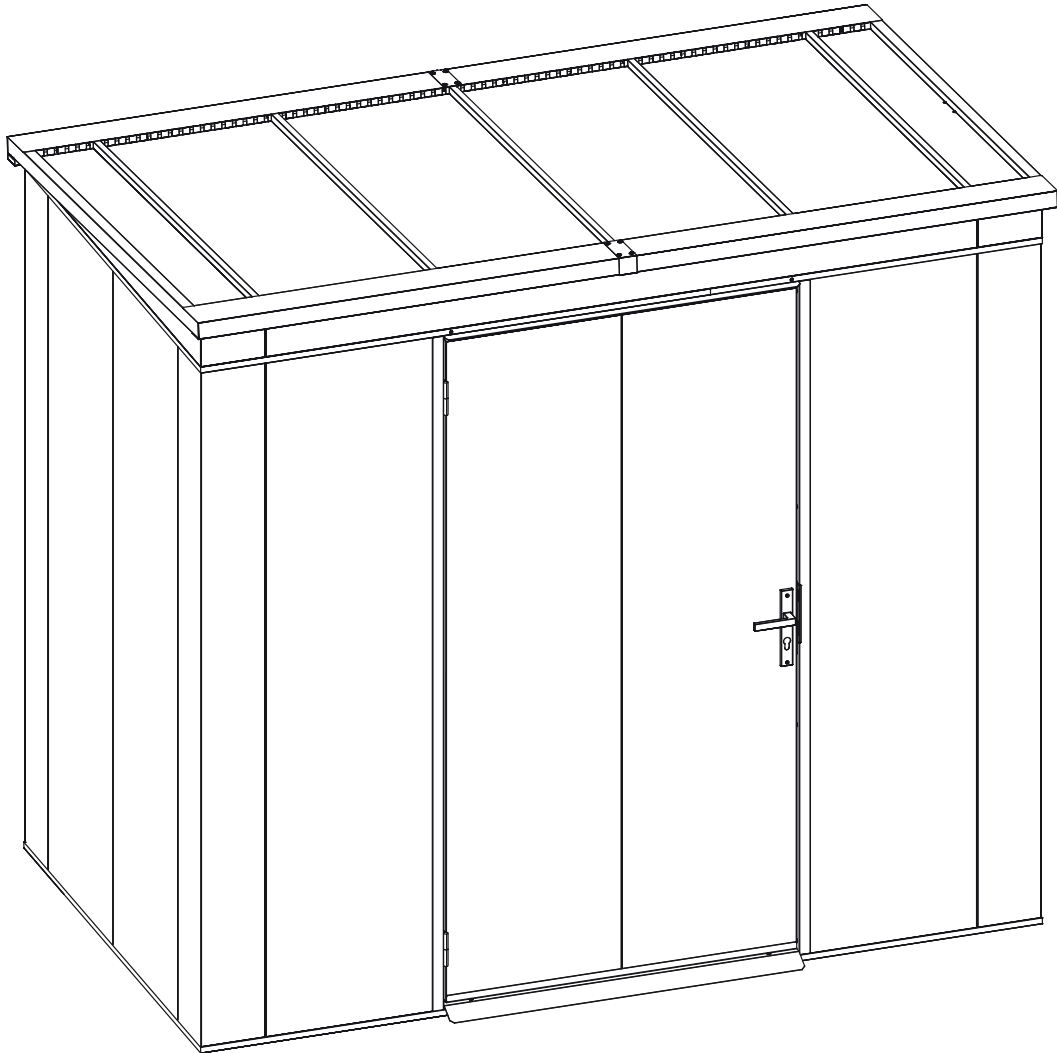

**Montageanleitung/
Assembly instructions/
Instructions de montage**

www.weka-holzbau.com

weka Holzbau GmbH
Postfach 20 02 04
D-17013 Neubrandenburg

Sie erreichen uns/ You can reach
us/ Vous pouvez nous joindre:
Mo - Fr 08:30 - 16:30 Uhr
+49 (0)395/42908-0

Sicherheitshinweise/ safety instructions/ Consignes de sécurité

Die Hinweise gelten für folgende Artikel/ The information applies to the following items/
Les informations s'appliquent aux éléments suivants:
70224140600, 70224140700

1. Montageteam/Assembly Team/ Nombre de personnes requises pour montage

DE: Die Montage muss stets von zwei Personen durchgeführt werden.

EN: Assembly must always be carried out by two people.

FR : Le montage doit toujours être effectué par deux personnes.

2. Schutzausrüstung & Unterlage/ Protective Equipment & Surface Protection/ Équipement de protection et support

DE: Tragen Sie bei der Montage Arbeitshandschuhe.

Verwenden Sie eine geeignete Unterlage, um Kratzer zu vermeiden.

EN: Wear work gloves during assembly.

Use a suitable surface protector to avoid scratches.

FR : Portez des gants de travail pendant le montage.

Utilisez une protection de surface appropriée pour éviter les rayures.

3. Beschädigte Teile/ Damaged Parts/ Pièces endommagées

DE: Installieren Sie keine beschädigten Bauteile.

Festgestellte Schäden müssen mit aussagekräftigen Fotos an uns gemeldet werden.

Bereits verbaute Teile gelten als akzeptiert.

EN: Do not install any damaged components.

Report all identified damage to us with meaningful photos.

Parts that have already been installed are considered accepted.

FR : N'installez aucun composant endommagé.

Signalez-nous tout dommage constaté en joignant des photos claires et explicites.

Les pièces déjà installées sont considérées comme acceptées.

4. Schraubverbindungen/ Screw Connections/ Assemblages vissés

DE: Ziehen Sie alle Schraubverbindungen erst nach vollständiger Montage fest.

EN: Tighten all screw connections only after the assembly has been fully completed.

FR: Serrez à fond les connexions vissées uniquement une fois l'assemblage entièrement terminé

5. Standsicherheit & Wetter/ Stability & Weather Conditions/ Stabilité et conditions météorologiques

DE: Sorgen Sie für eine sturmsichere Bodenverankerung.

Stellen Sie das Produkt nicht bei Wind auf.

EN: Ensure the product is securely anchored to the ground to withstand strong winds.

Do not assemble the product in windy conditions.

FR: Assurez-vous le produit soit solidement ancré, pour résister aux vents forts.

Ne pas assembler l'abri en cas de vents importants.

6. Kindersicherheit und scharfe Kanten/ Child Safety and Sharp Edges/ Sécurité des enfants et arêtes vives

DE: Halten Sie Kleinteile und Verpackungsmaterial während der Montage von Kindern fern.
Bauteile können scharfe Kanten oder hervorstehende Teile aufweisen.

Achten Sie darauf sowohl bei der Montage als auch im täglichen Gebrauch.

EN: Keep small parts and packaging materials away from children during assembly.
Components may have sharp edges or protruding parts.

Pay attention to this during assembly and during everyday use

FR : Gardez les petites pièces et les matériaux d'emballage hors de portée des enfants pendant le montage.

Les composants peuvent présenter des arêtes vives ou des parties saillantes.

Faites attention à cela lors du montage ainsi que pendant l'utilisation quotidienne.

7. Sicherheit bei hohen Temperaturen/ Sicherheit bei hohen Temperaturen/ Sécurité à haute température

DE: Im Sommer können im Innenraum sehr hohe Temperaturen auftreten.

EN: During summer, very high temperatures may occur inside the house.

FR : En été, des températures très élevées peuvent survenir à l'intérieur de la maison.

8. Abdeckungen/ Covers/ Couvertures

DE: Verwenden Sie keine Abdeckungen oder Hüllen für das Produkt.

EN: Do not use covers or tarpaulins on the product.

FR : Ne jamais recouvrir l'abri avec une housse ou une bâche.

9. Untergrund/ Ground Surface/ Surface du sol

DE: Das Produkt darf nur auf einem geeigneten, festen und ebenen Untergrund montiert werden.

EN: The product may only be assembled on a suitable, solid, and level surface.

FR : Le produit doit être monté uniquement sur une surface appropriée, solide et plane.

10. Transport

DE: Das Produkt ist nicht für den Transport im montierten Zustand geeignet.

Es muss am finalen Aufstellungsort montiert werden, um Transportschäden zu vermeiden.

EN: The product is not suitable for transport in assembled condition.

It must be assembled at its final installation location to avoid transport damage.

FR : Ne jamais transporté le produit déjà monté. Il ne doit être monté qu'à son emplacement final d'utilisation, afin d'éviter tout dommage lié au transport.

11. Garantiehinweis/ Warranty Notice/ Avis de garantie

DE: Bitte beachten Sie – Jegliche Änderungen oder Modifikationen am Produkt führen zum Erlöschen der Garantie.

EN: Please note – Any changes or modifications to the product will void the warranty.

FR : Veuillez noter : toute modification ou transformation du produit entraîne l'annulation de la garantie.

Pflege und Wartung / Care and Maintenance/ Entretien et maintenance

1. Chemikalien & Reinigung/ Chemicals & Cleaning/ Produits chimiques et nettoyage

DE: Lagern Sie keine aggressiven Chemikalien wie Chlor oder Streusalz in oder am Produkt.
Verwenden Sie keine scheuernden Reinigungsmittel. Sonnenmilch und andere Cremes mit Wasser und Seife entfernen!

EN: Do not store aggressive chemicals such as chlorine or road salt in or near the product.
Do not use abrasive cleaning agents. Remove sunscreen and other creams with soap and water!

FR : Ne stockez pas de produits chimiques agressifs tels que le chlore ou le sel de déneigement dans ou à proximité du produit. N'utilisez pas de produits de nettoyage abrasifs.
Enlevez la crème solaire et les autres crèmes avec de l'eau et du savon.

2. Schnee & Schneelast/ Snow & Snow load/ Neige et charge de neige

DE: Entfernen Sie regelmäßig Schnee vom Dach, um die maximale Schneelastgrenze nicht zu überschreiten und Einsturzgefahren vorzubeugen

EN: Regularly remove snow from the roof to avoid exceeding the maximum snow load limit and prevent the risk of collapse.

FR: En cas de neige, déneigez régulièrement le toit afin de ne pas dépasser la charge maximale de neige admissible et d'éviter tout risque d'effondrement.

3. Schloss/ Lock/ Serrure

DE: Ölen Sie das Schloss jährlich!

EN: Oil the lock annually!

FR : Veillez à lubrifier la serrure une fois par an !

4. Schraubverbindungen/ Screw Connections/ Connexions vissées

DE: Schraubverbindungen regelmäßig kontrollieren!

EN: Check screw connections regularly!

FR : Vérifiez régulièrement les assemblages vissés !

Stückliste / Component list/ Liste des pièces

Element-Name/ Element name/ Nom de l'élément	Menge/ Quantity/ Quantité	Element-Nr./ Element No./ N° d'élément
Eckpanel/ Corner panel/ Panneau d'angle	4	4
Gerades Panel/ Straight panel/ Panneau droit	7	5
Gerades Panel mitte/ Straight panel middle/ Panneau droit au centre	1	58
Panel Scharnier/ Hinge panel/ Panneau charnière	1	59
Panel Schloss/ Lock panel/ Panneau serrure	1	60
Schräge Wand links 1/ Sloped wall left 1/ Paroi inclinée gauche 1	1	32
Schräge Wand rechts 1/ Sloped wall right 1/ Paroi inclinée droite 1	1	34
Wand oben 1A/ Upper wall 1A/ Paroi supérieure 1A	1	55
Wand oben 1B/ Upper wall 1B/ Paroi supérieure 1A	1	56
Wand oben 2/ Upper wall 2/ Paroi supérieure 2	1	54
Rinne unten links/ Bottom gutter left/ Gouttière inférieure gauche	1	61
Rinne unten rechts/ Bottom gutter right/ Gouttière inférieure droit	1	62
Rinne oben links/ Top gutter left/ Gouttière supérieure gauche	1	63
Rinne oben rechts/ Top gutter right/ Gouttière supérieure droit	1	64
Dach rechts/ Roof right/ Toit droit	1	35
Dach links/ Roof left/ Toit gauche	1	37
Dach mitte/ Roof center/ Toit central	4	36
Türleiste oben/ Top door strip/ Baguette de porte supérieure	1	25
Verstärkung Tür/ Door reinforcement/ Renfort de porte	2	26
Obere Schwelle/ Upper threshold/ Seuil supérieur	1	24
Untere Schwelle/ Lower threshold/ Seuil inférieur	1	22
Auffahrt/ Ramp/ Rampe d'accès	1	23
Schlossprofil/ Lock profile/ Profilé de serrure	1	21
Scharnierprofil/ Hinge profile/ Profilé de charnière	1	20
Verstärkungsbalken 2/ Reinforcement beam 2/ Poutre de renfort 2	2	57
Verstärkungsbalken 1/ Reinforcement beam 1/ Poutre de renfort 1	1	31
Untere Ecke/ Bottom corner/ Angle inférieur	4	3
Obere Ecke/ Top corner/ Angle supérieur	4	8
Türblatt Scharnier/ Door leaf hinge side/ Vantail de porte – charnière	1	27
Türblatt Schloss/ Door leaf lock side/ Vantail de porte – serrure	1	28

Stückliste / Component list/ Liste des pièces

Element-Name/ Element name/ Nom de l'élément	Menge/ Quantity/ Quantité	Element-Nr./ Element No./ N° d'élément
Unterprofil 1868/ Bottom profile 1868/ Profilé inférieur 1868	4	30
Unterprofil 1435 R/ Bottom profile 1435 R/ Profilé inférieur 1435 R	2	48
Unterprofil 934 L/ Bottom profile 934 L/ Profilé inférieur 934 L	2	49
Unterprofil 1435 L/ Bottom profile 1435 R/ Profilé inférieur 1435 L	2	50
Unterprofil 934 R/ Bottom profile 934 R/ Profilé inférieur 934 R	2	51
Schlossblech/ Strike plate/ Gâche de serrure	1	29
Verbinder/ Connector/ Connecteur	2	77
Rinnenverbinder unten/ Bottom gutter connector/ Raccord de gouttière inférieur	1	115
Rinnenverbinder oben/ Top gutter connector/ Raccord de gouttière (partie supérieure)	1	116

Fundament/ Foundation/ Fondation

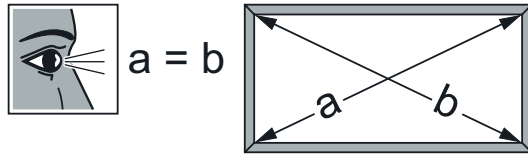

A

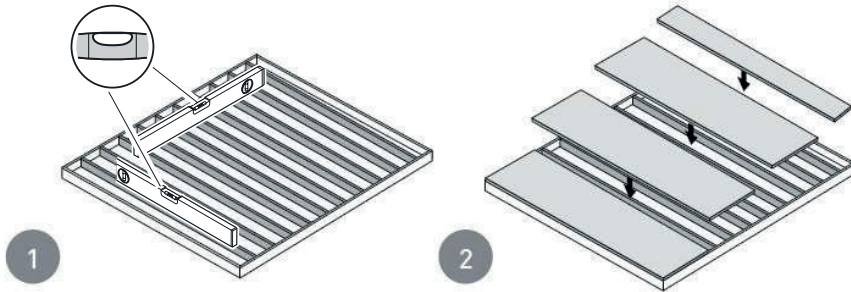

B

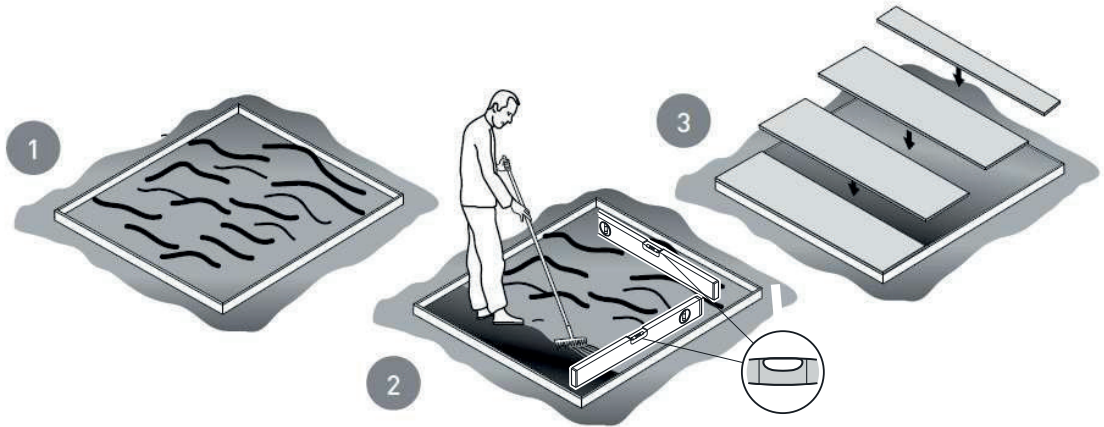

C

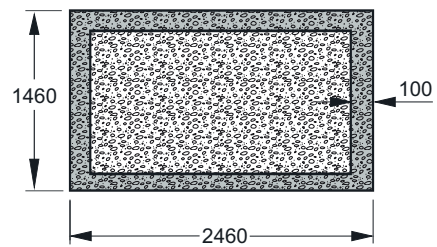
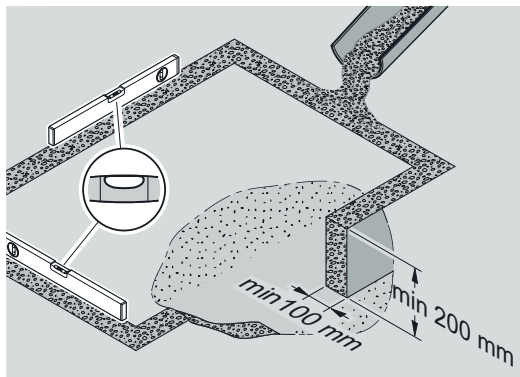

Teileübersicht/ Summary of Components/ Liste des composants

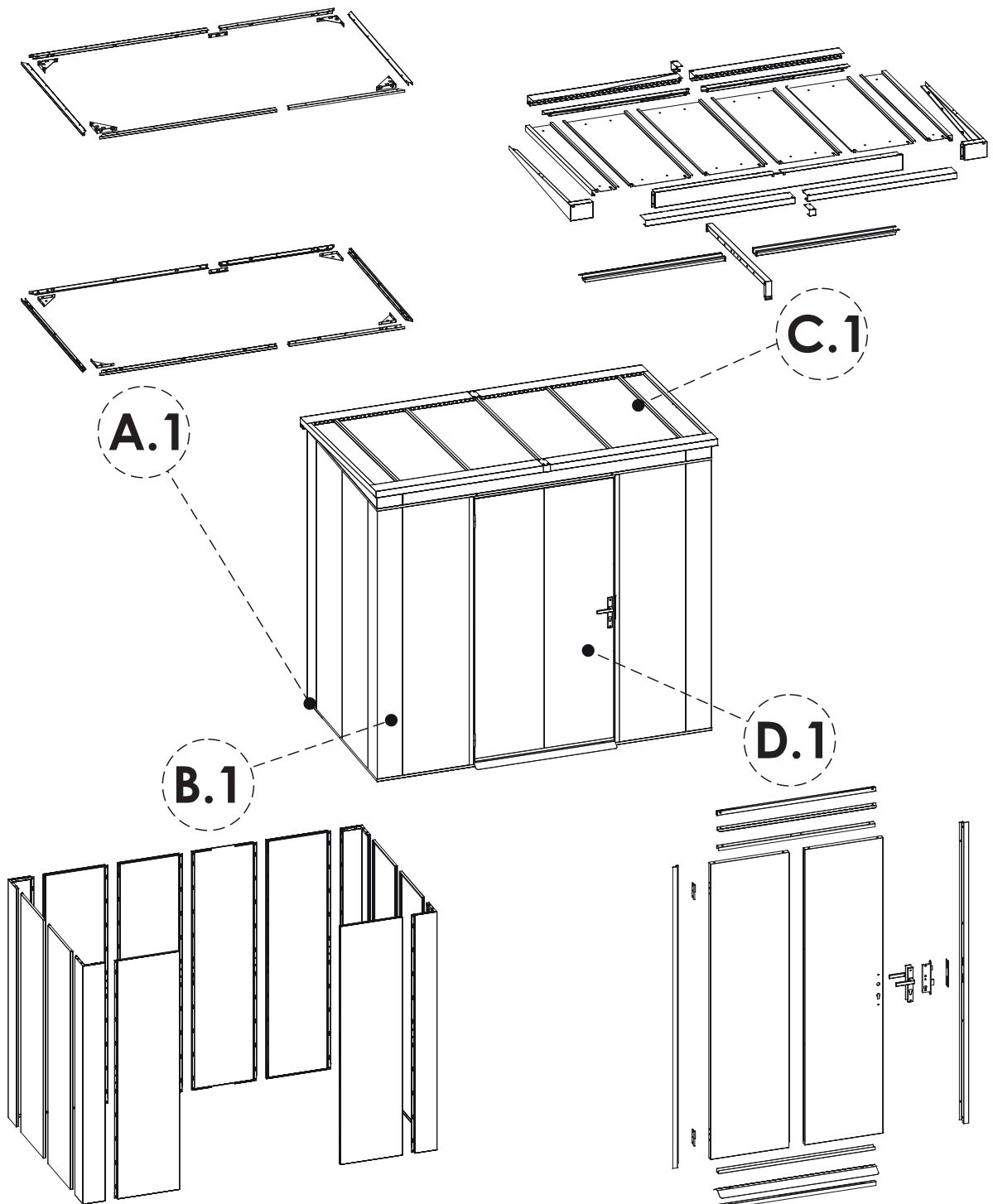
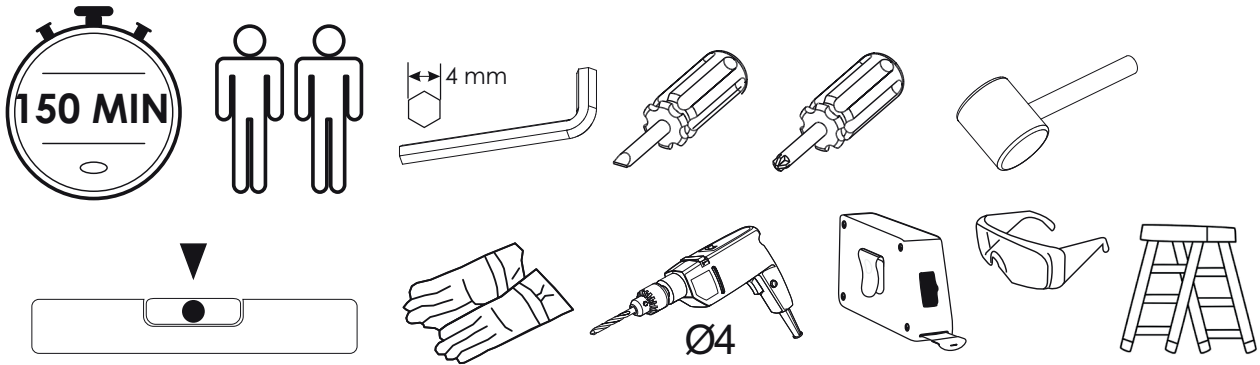

Teileübersicht/ Summary of Components/ Liste des composants

A1

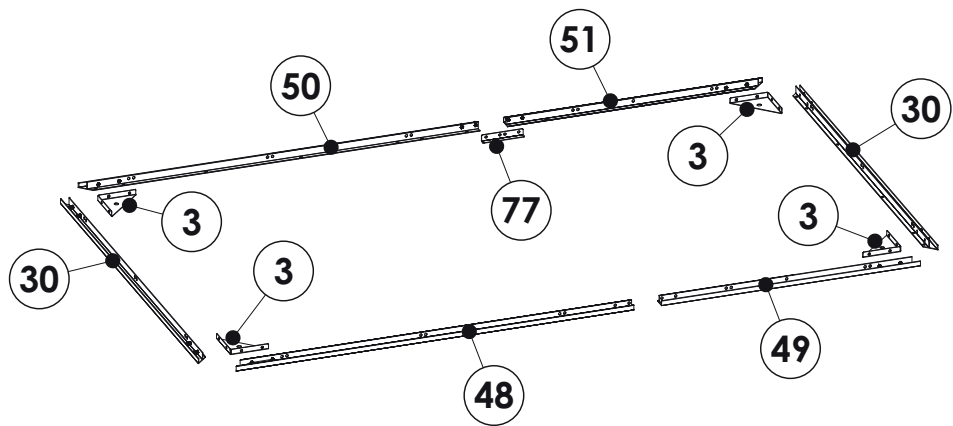
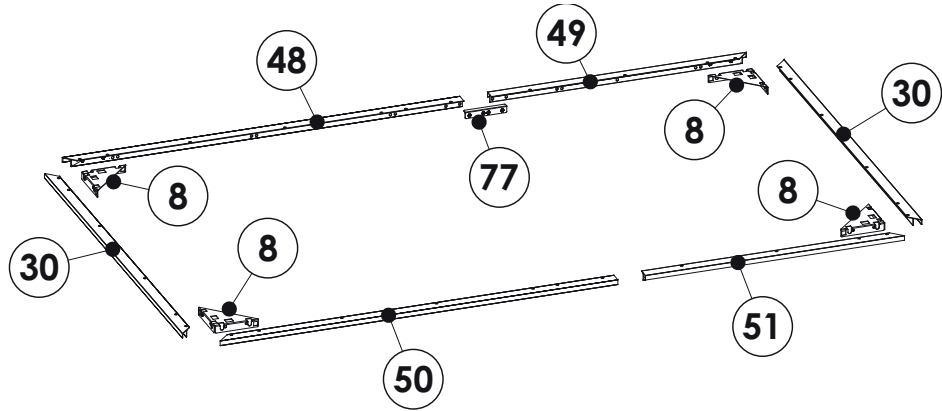

B1

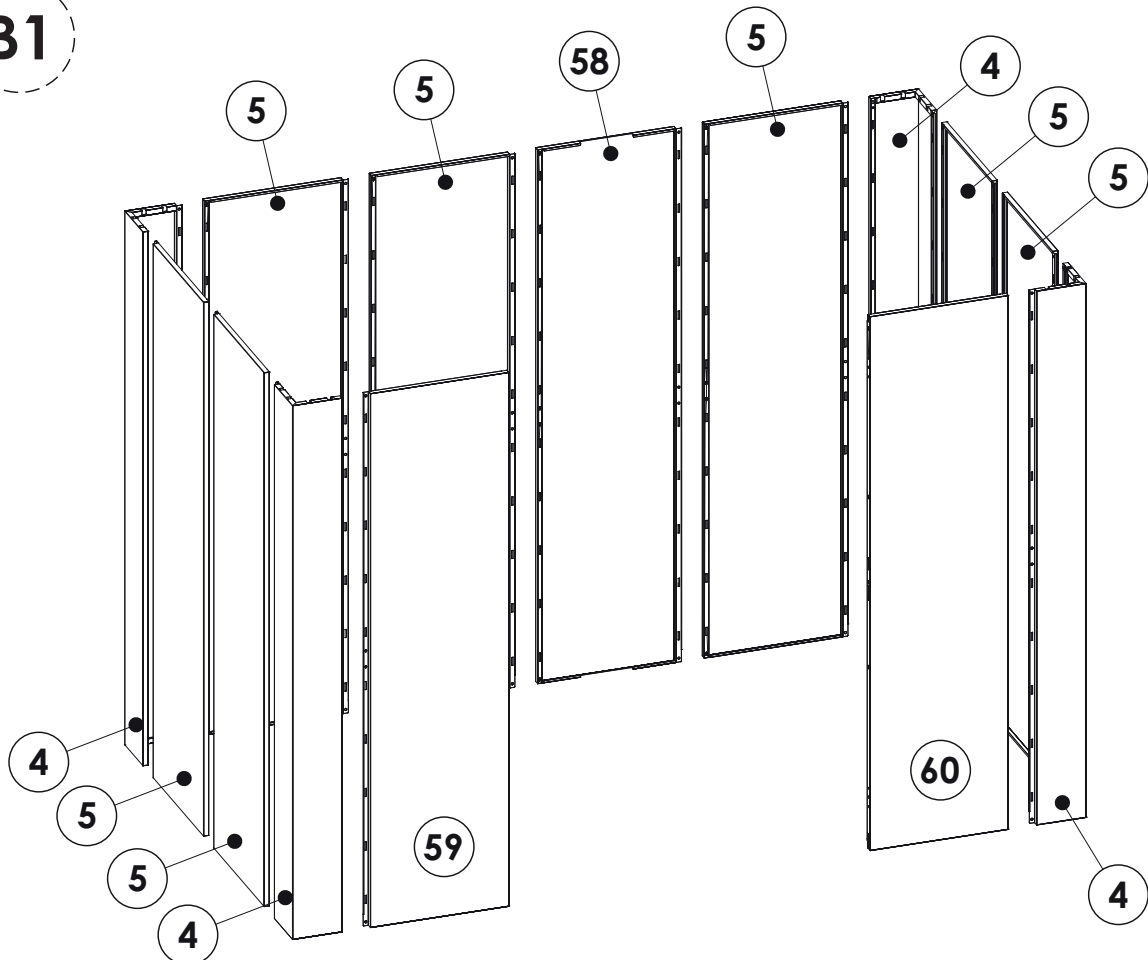





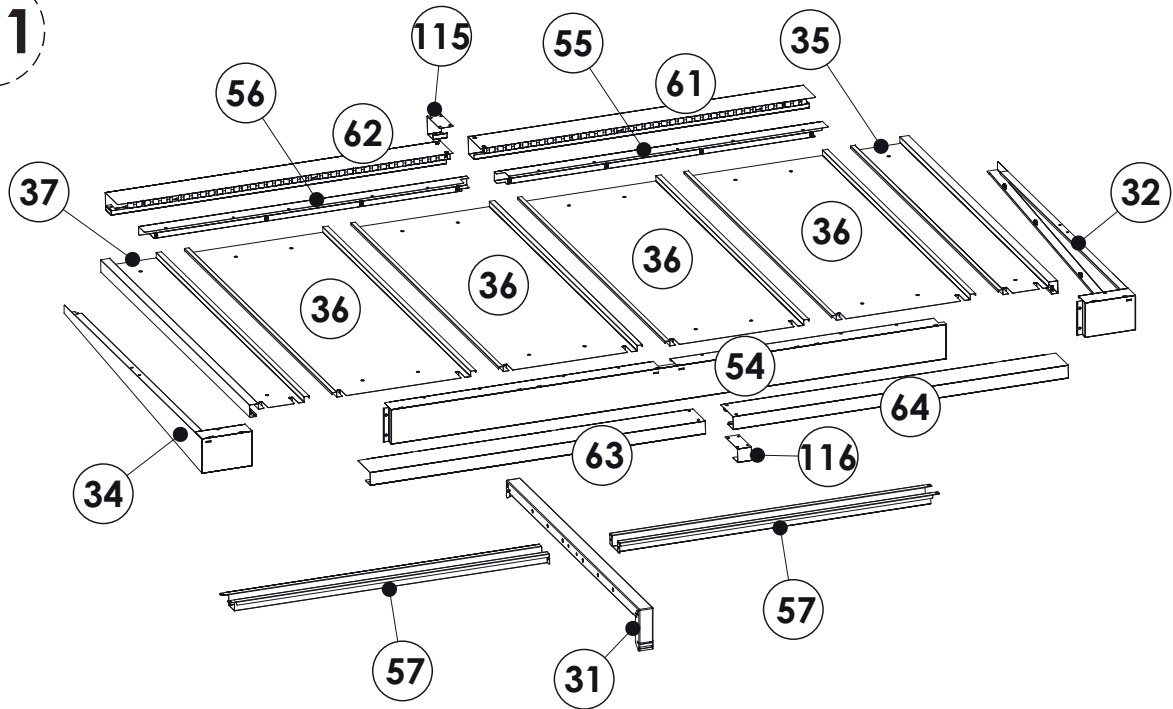

Teileübersicht/ Summary of Components/ Liste des composants

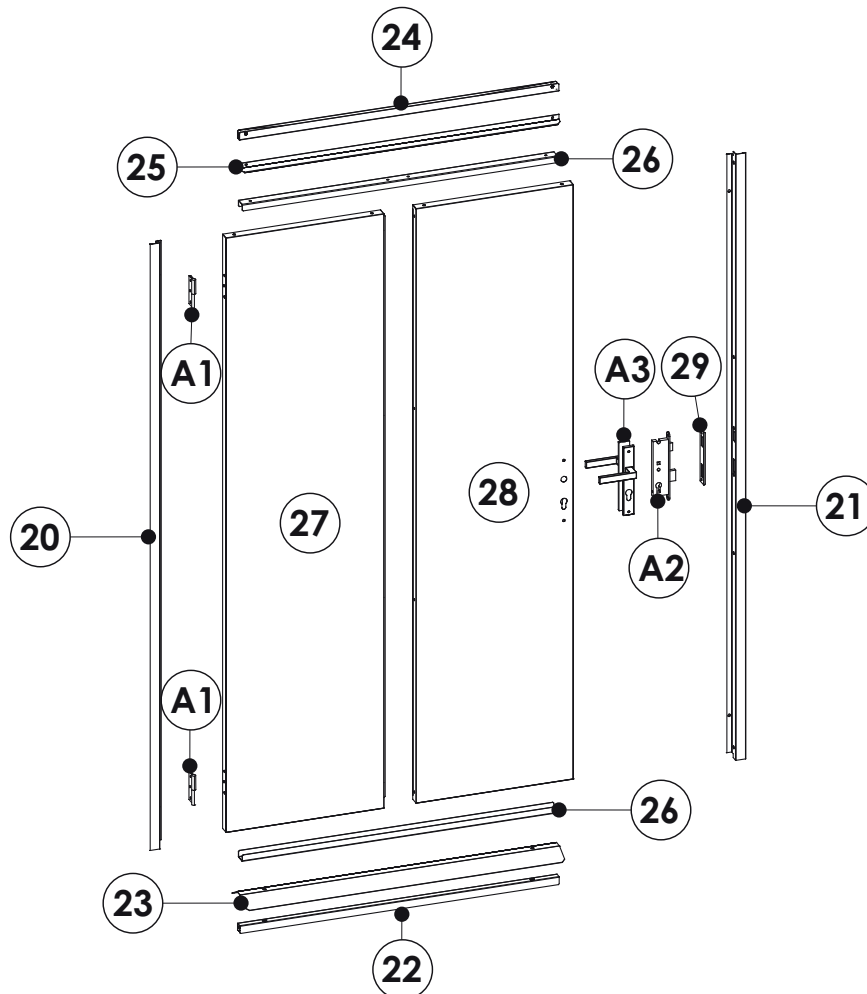
C1

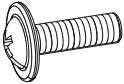

D1



S1 x175  M6 x 16 mm	S2 x14  M5 x 10 mm	S3 x20  M4 x 10 mm	S4 x13  M6 x 12 mm	S5 x2 	U1 x1 
U2 x20 					

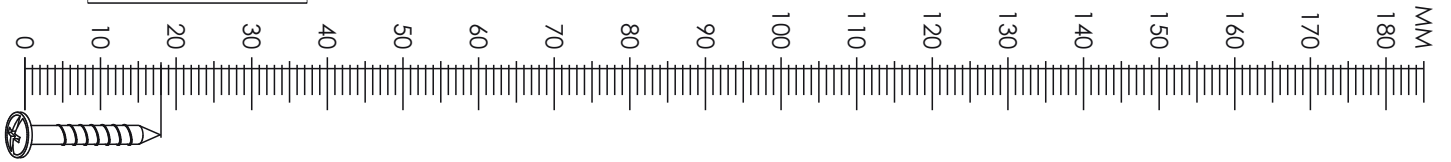

Installation

1

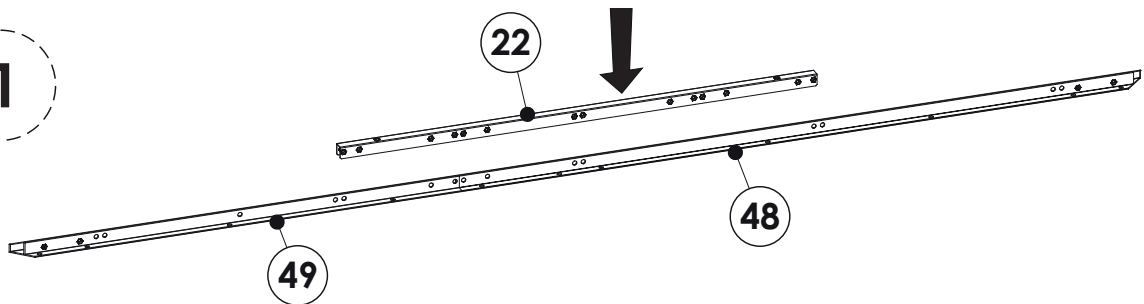

2

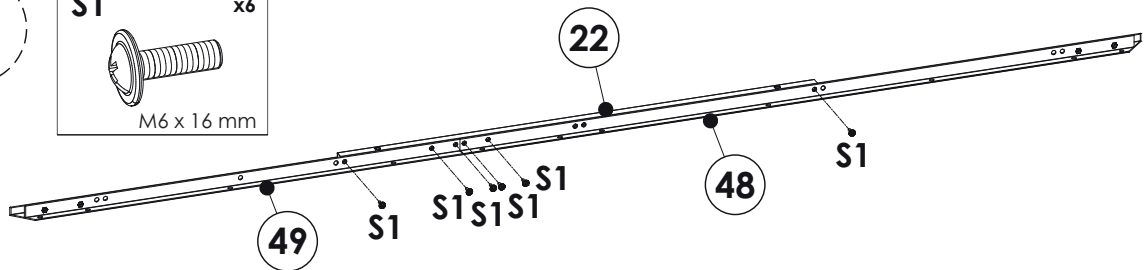
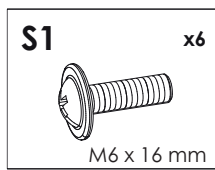

3

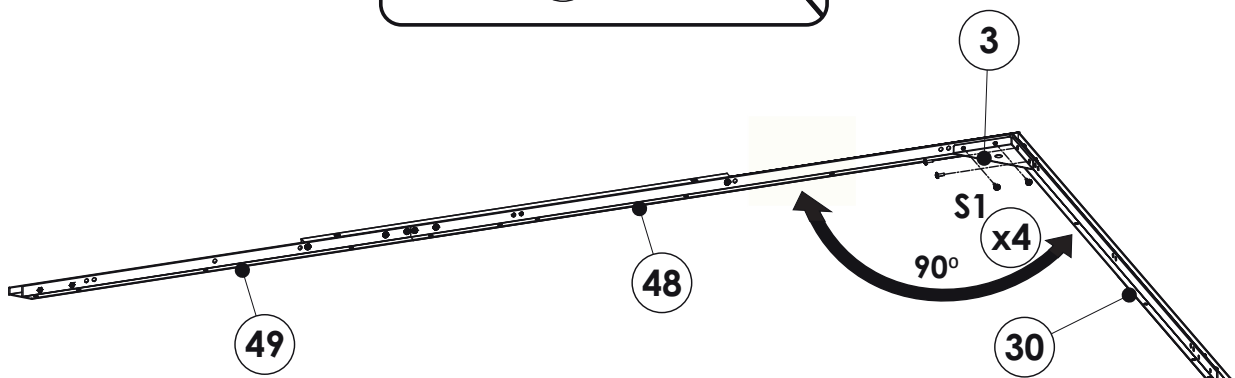
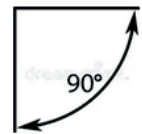
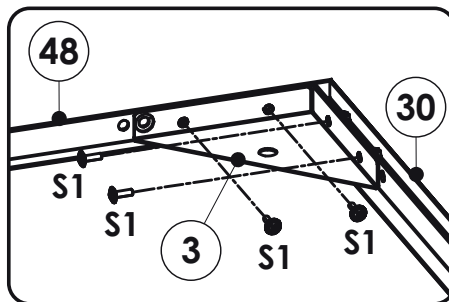
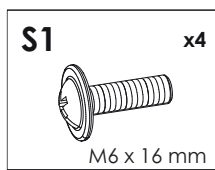

Installation

4

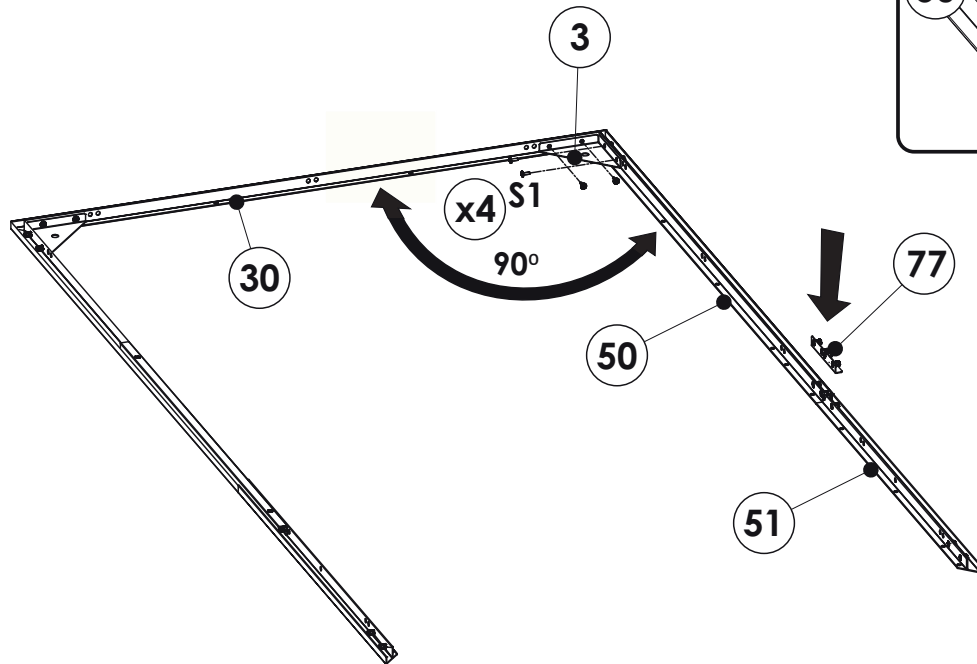
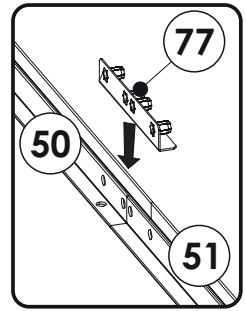
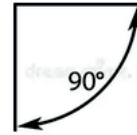
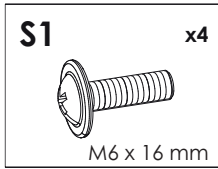

5

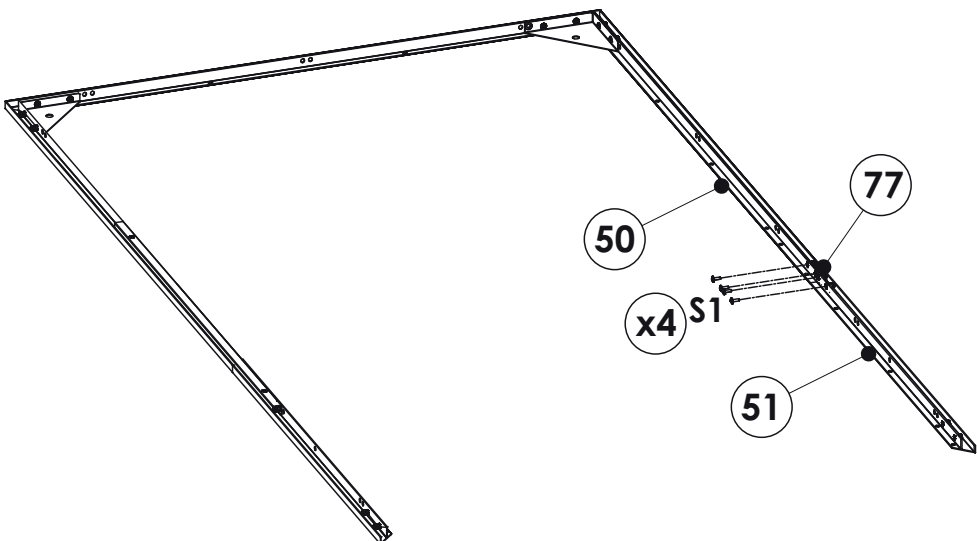
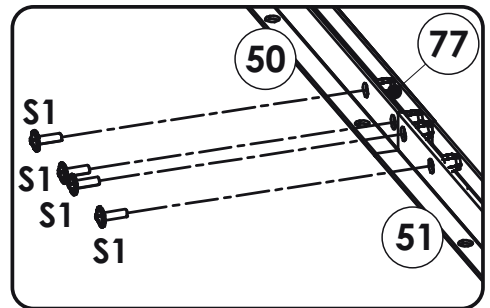
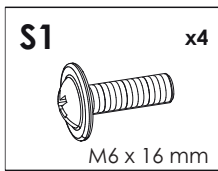

Installation

6

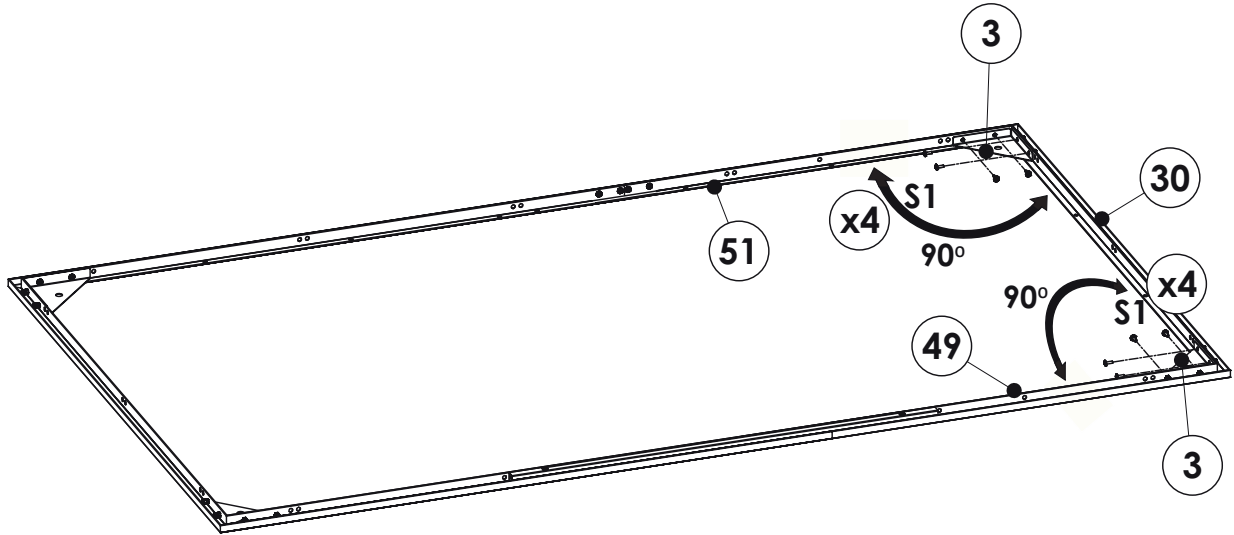
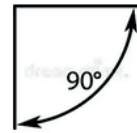
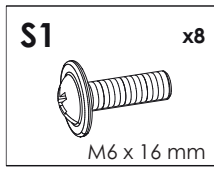

7

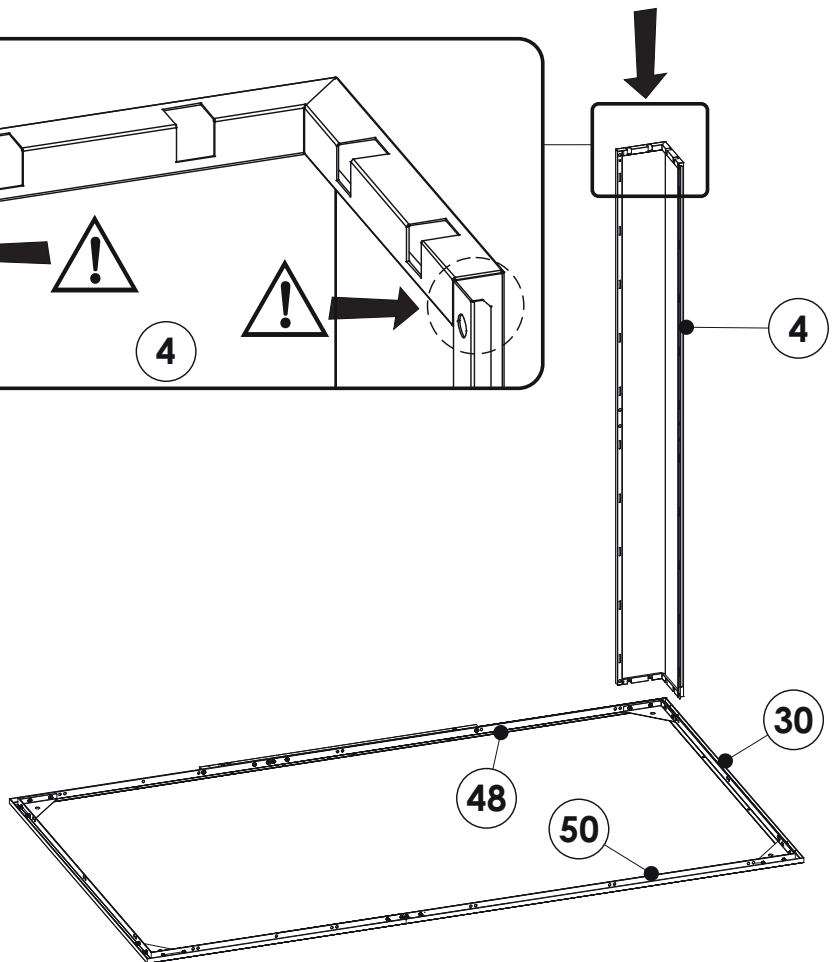
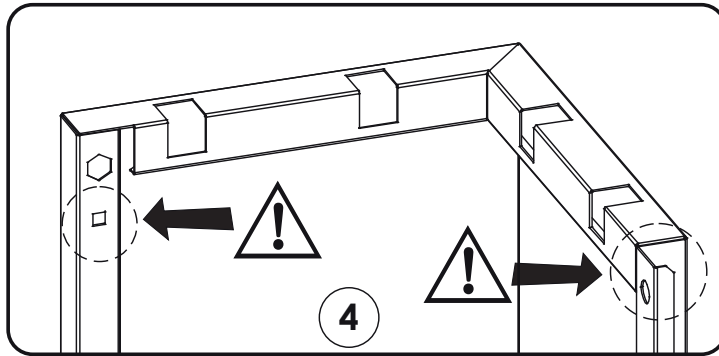
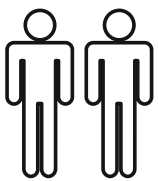

Installation

8

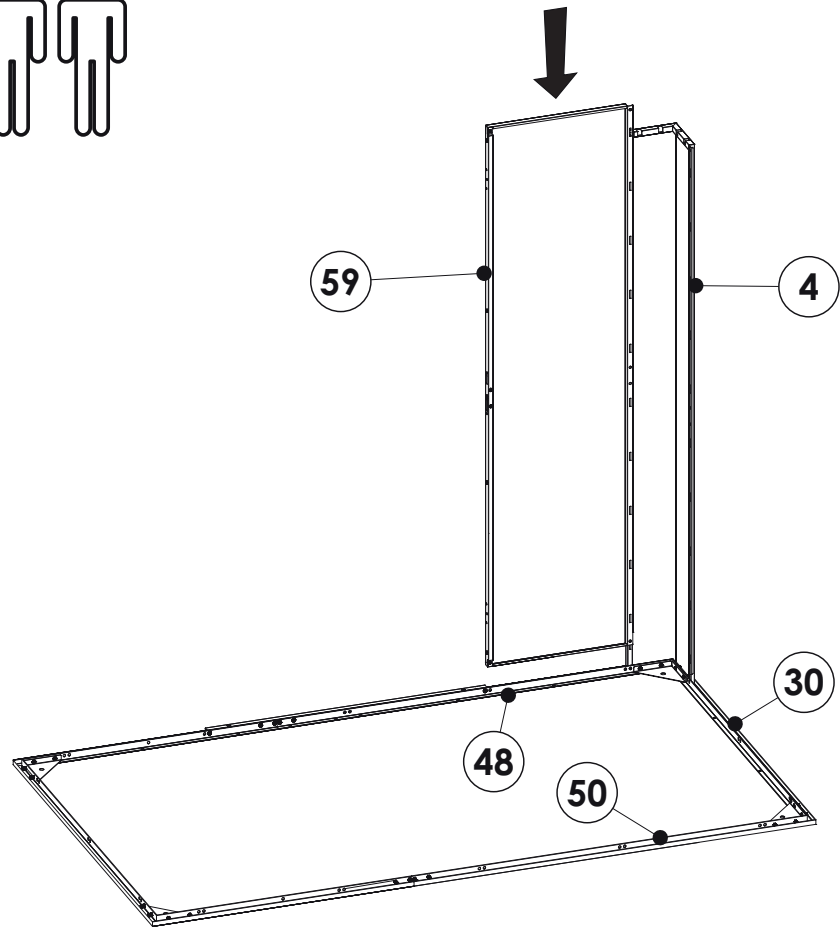
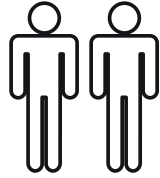

9

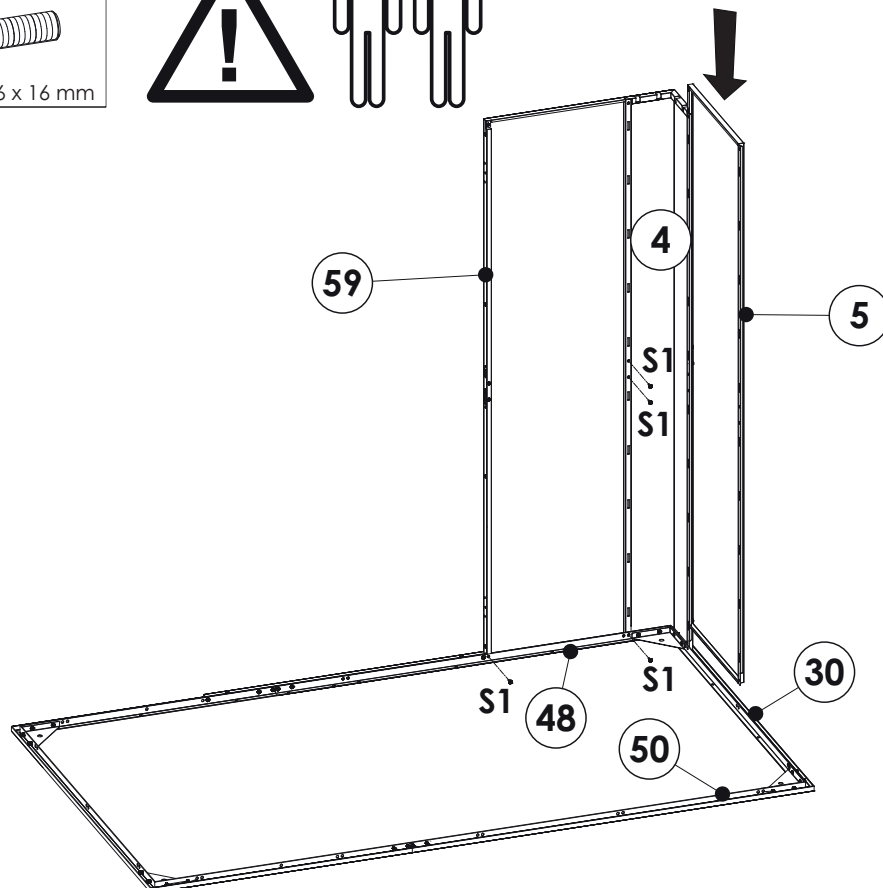
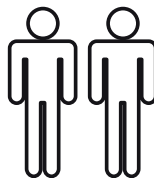
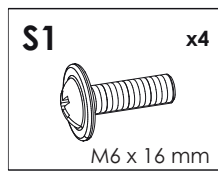

Installation

10

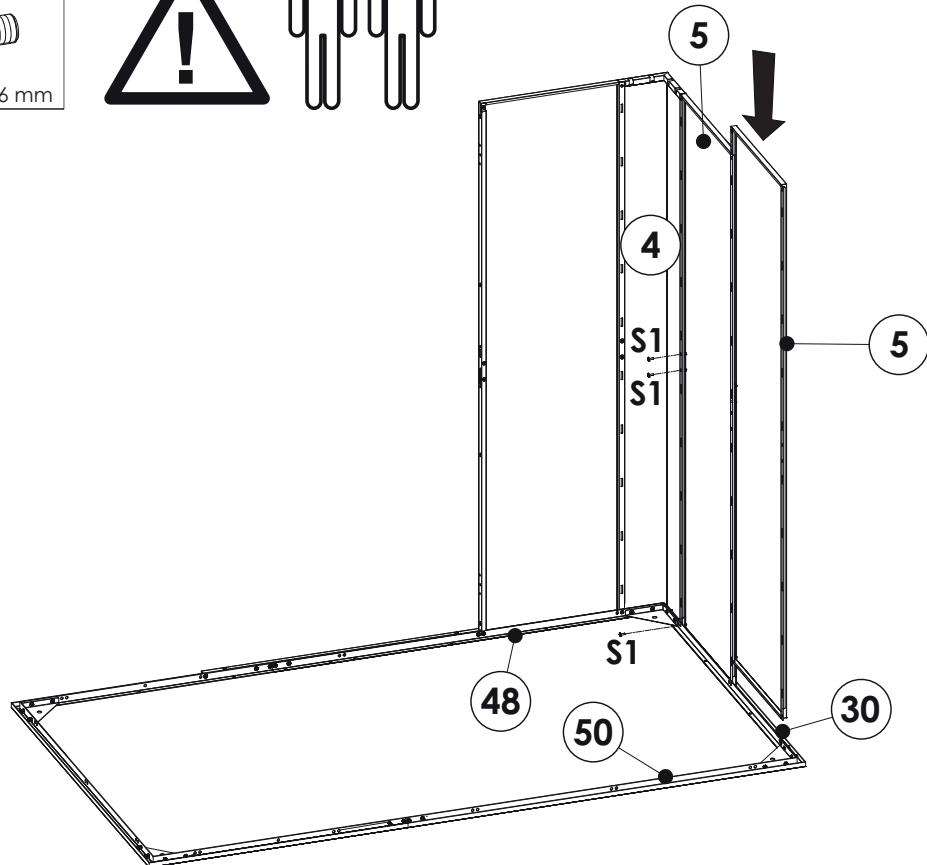
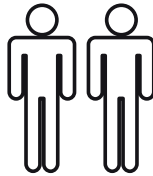
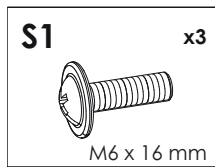

11

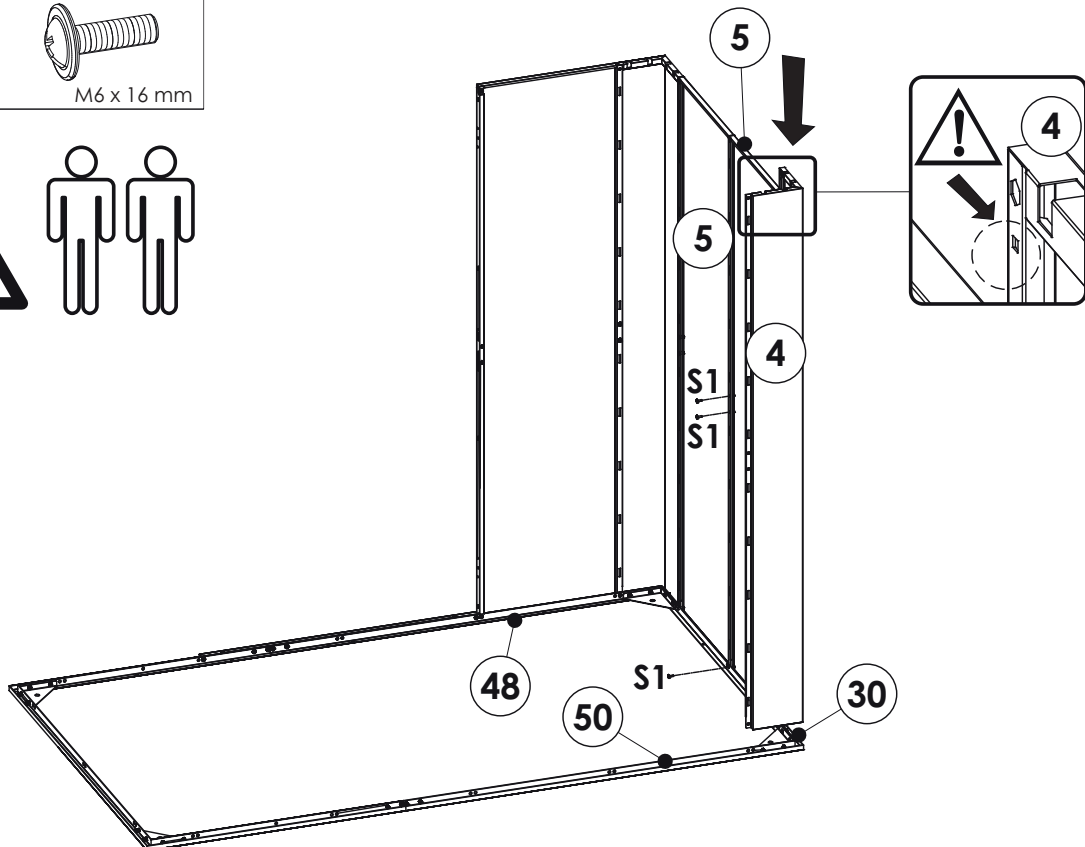
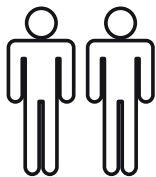
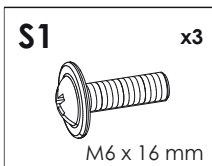

Installation

12

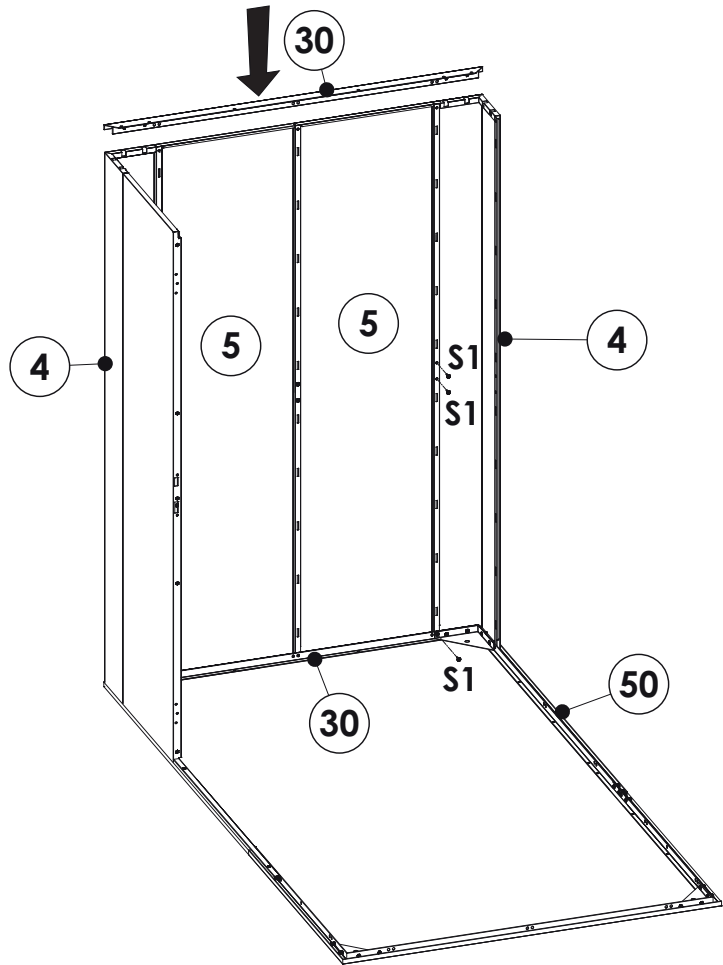
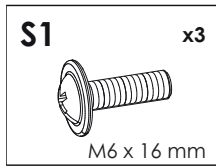

13

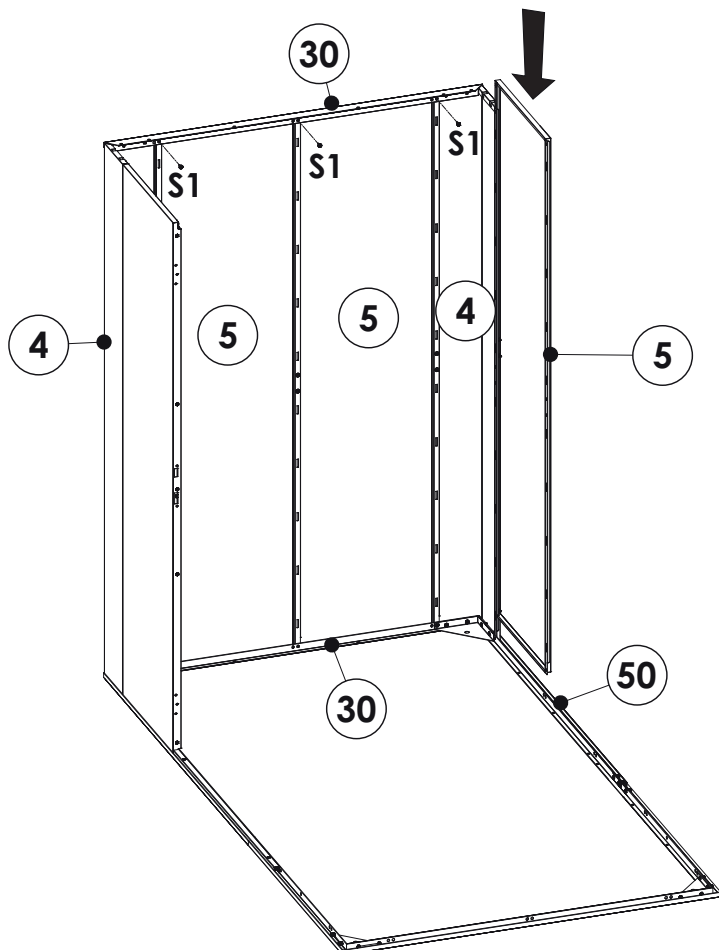
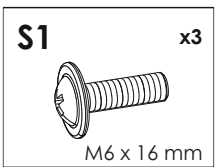

Installation

14

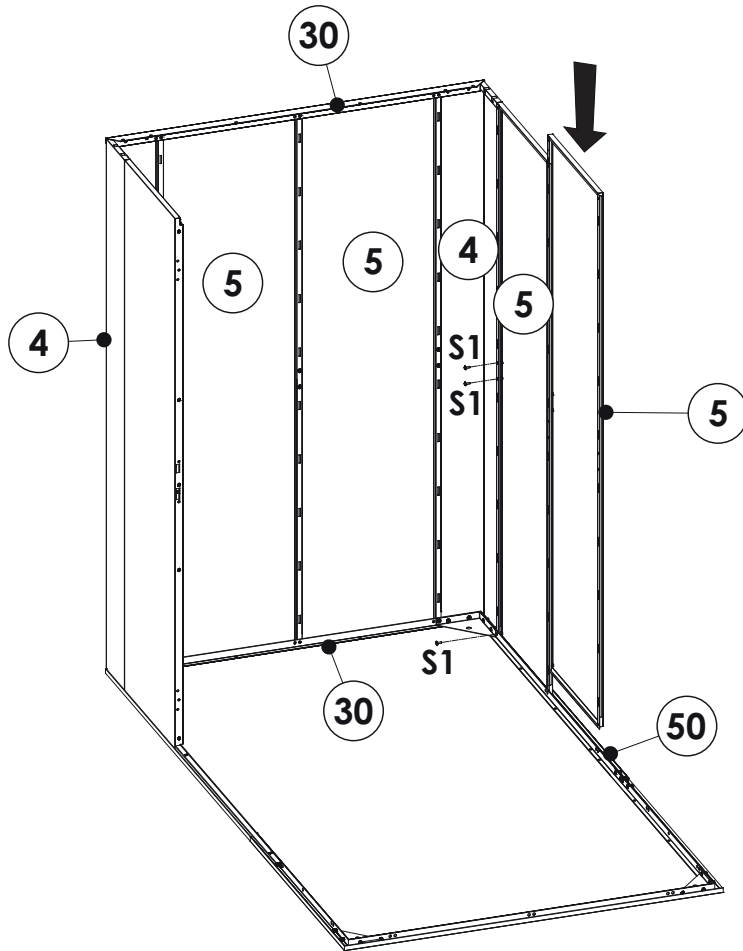
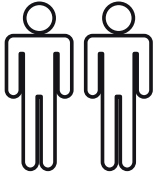
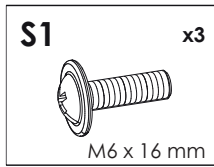

15

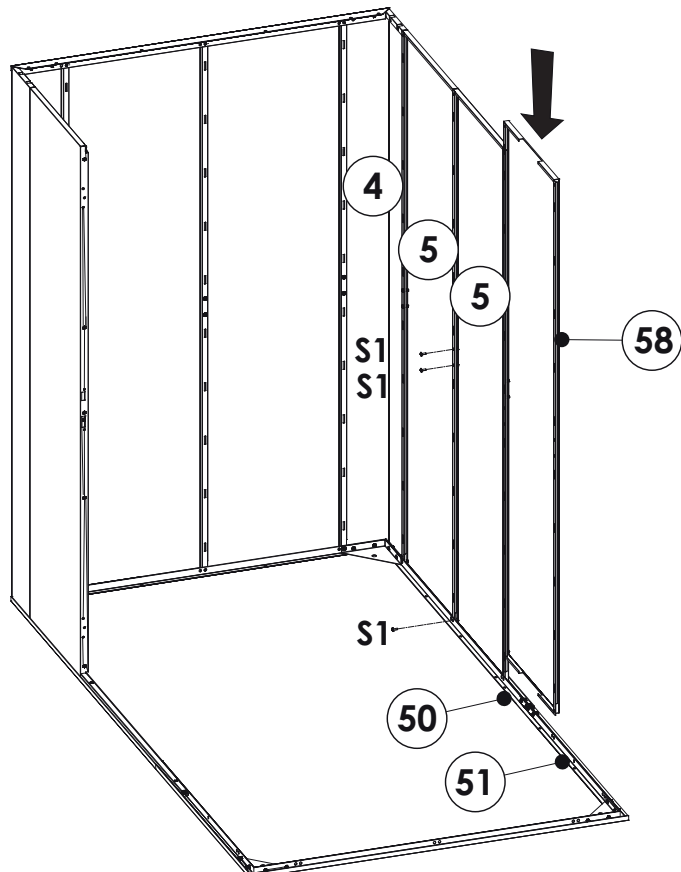
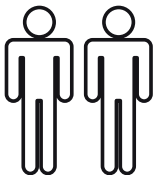
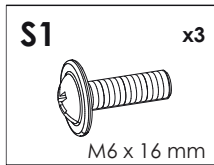

Installation

16

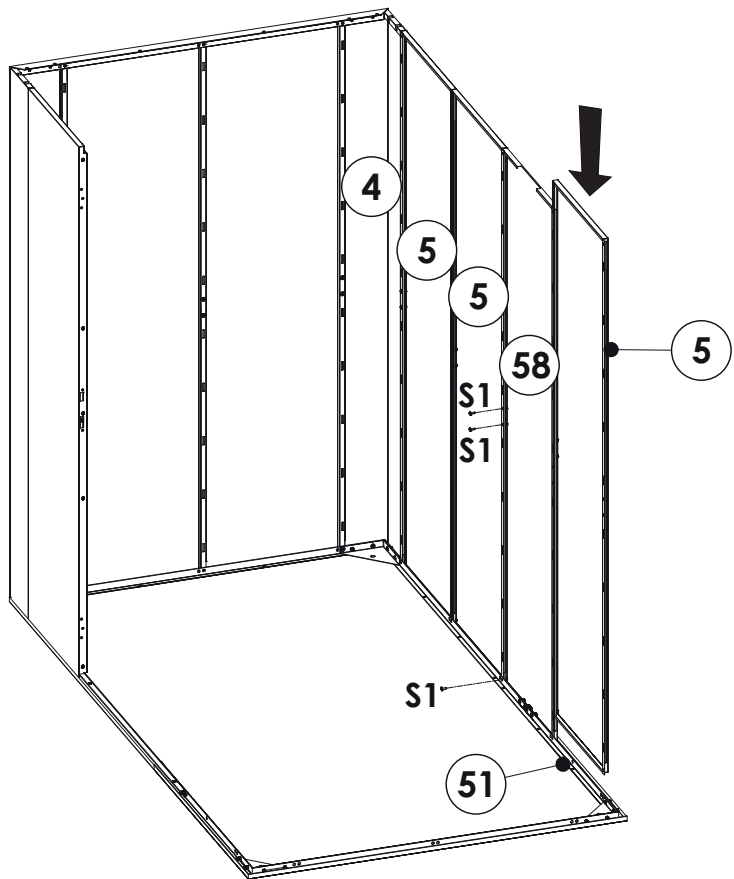
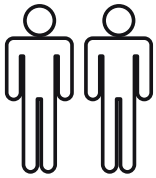
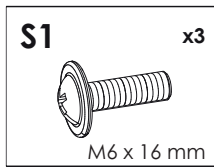

17

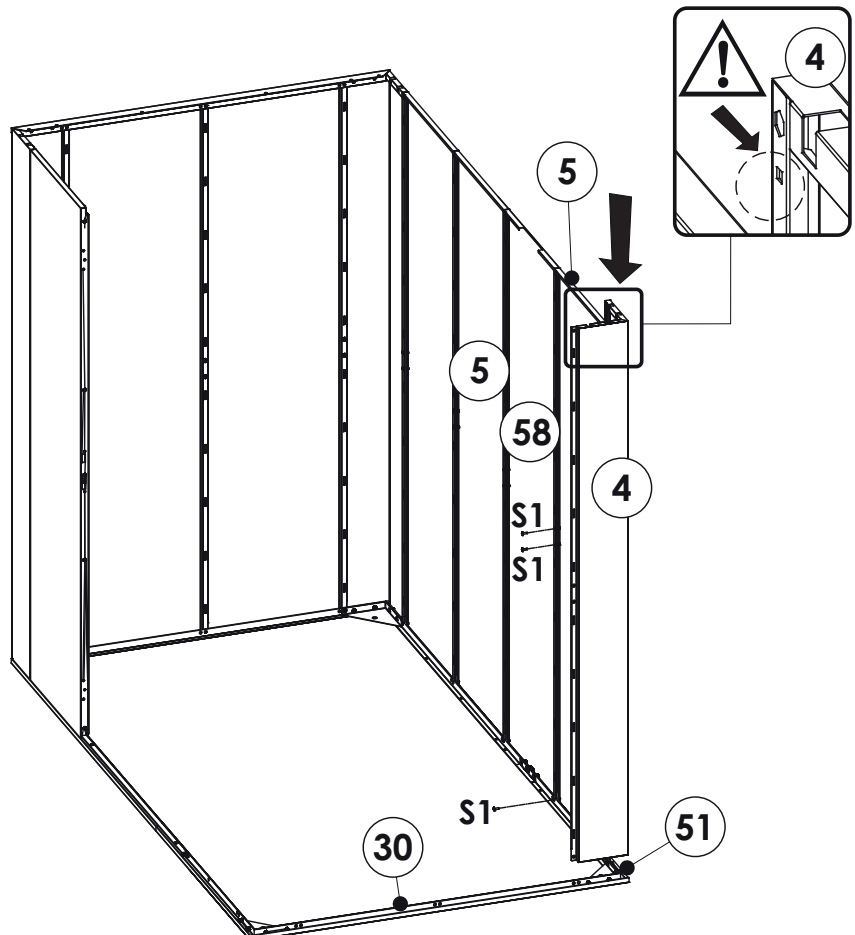
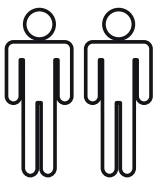
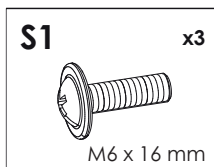

Installation

18

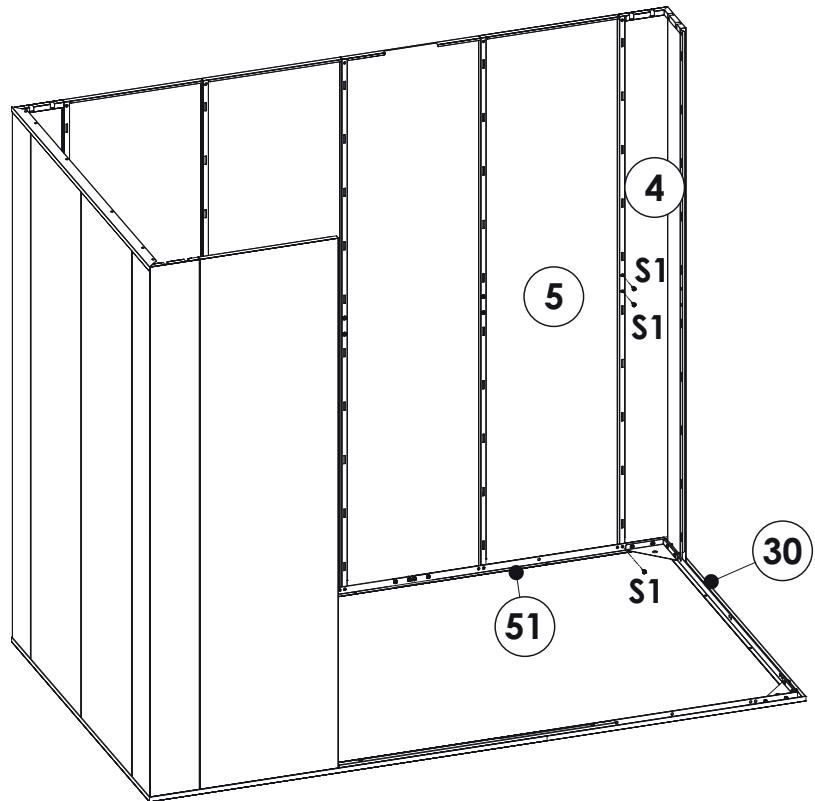
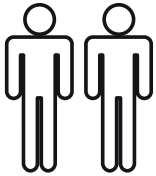
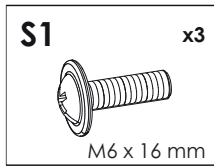

19

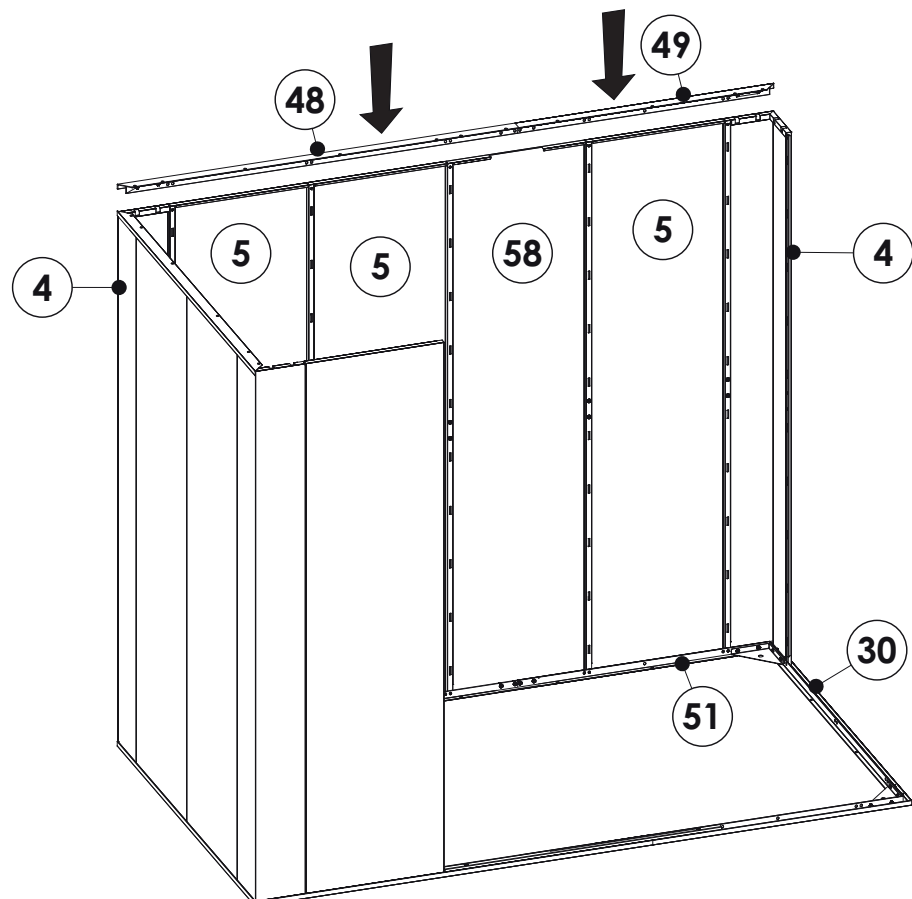
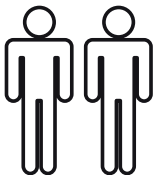

Installation

20

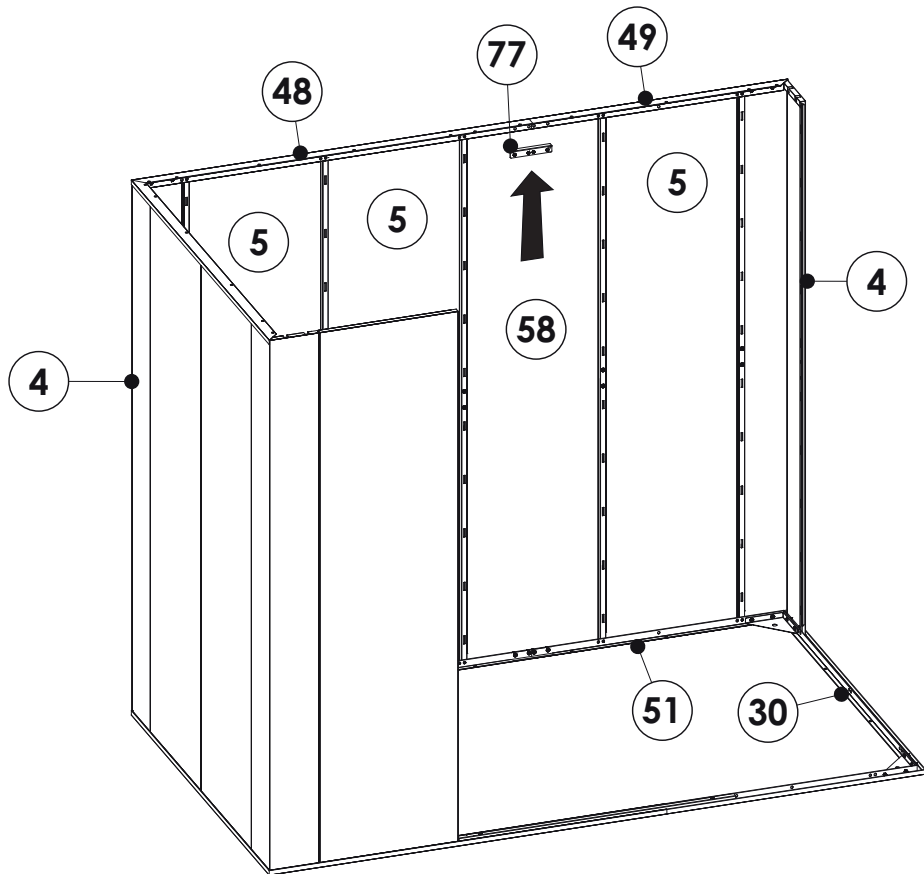

21

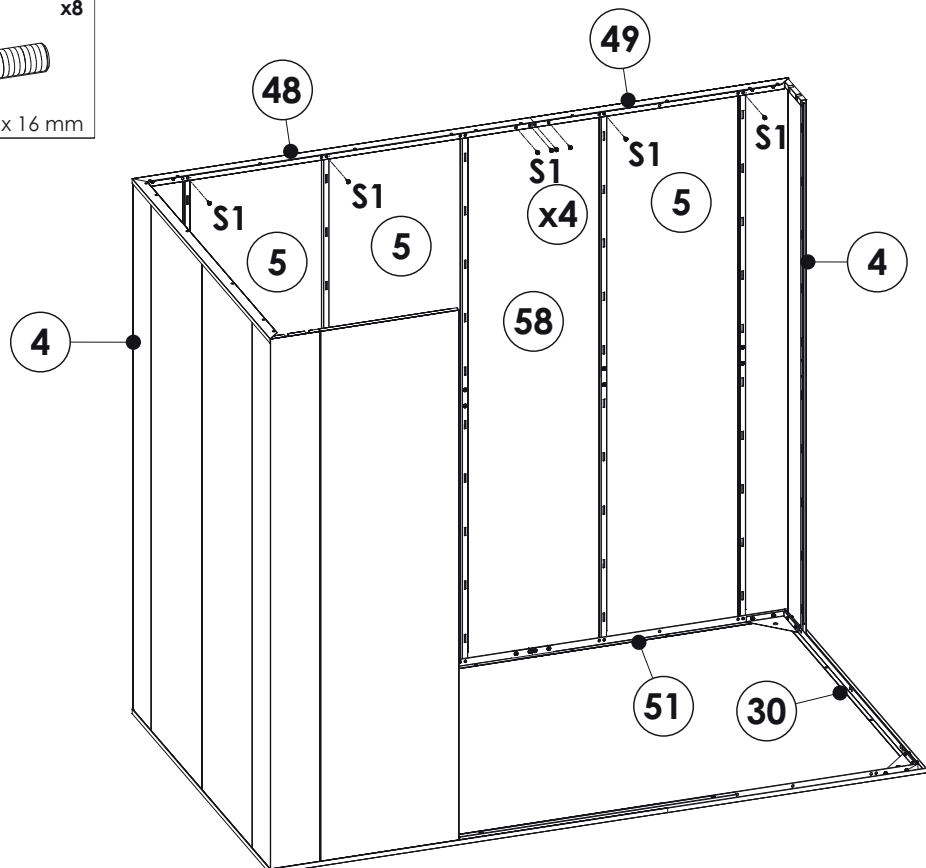
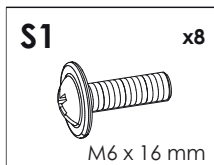

Installation

22

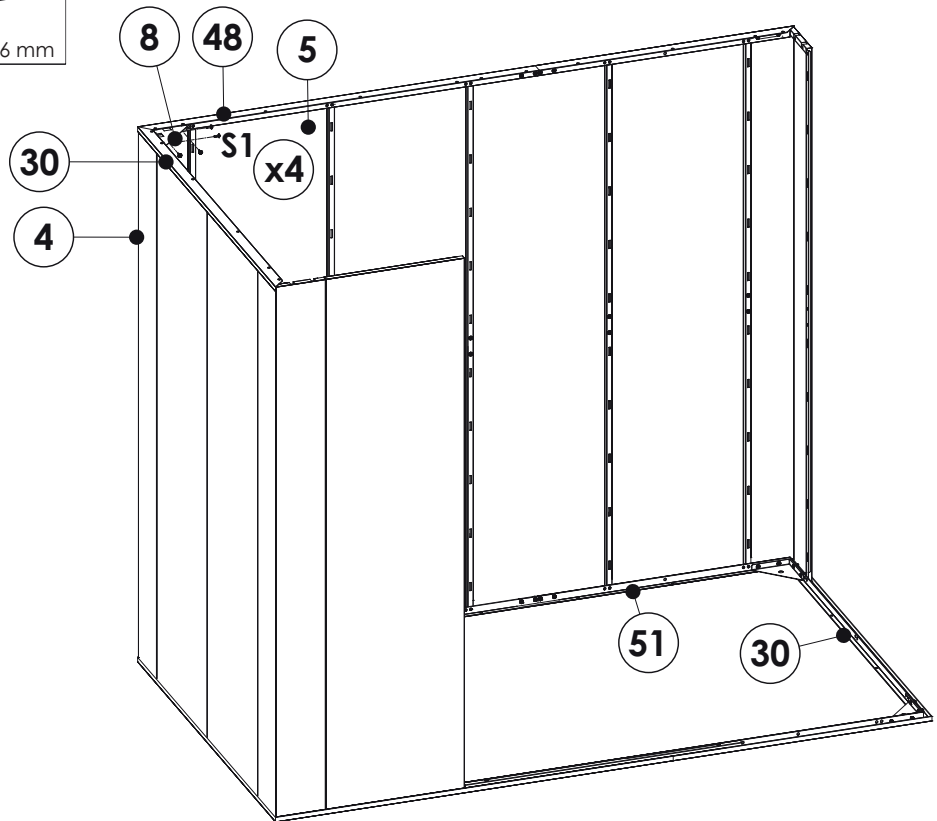
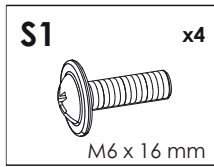

23

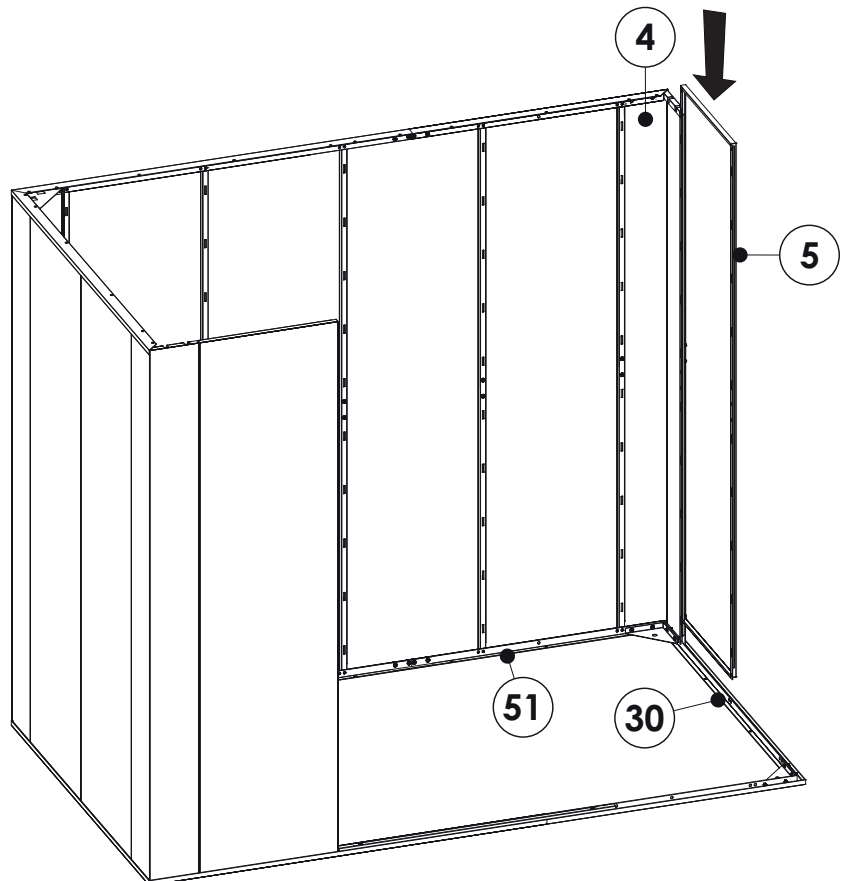

Installation

24

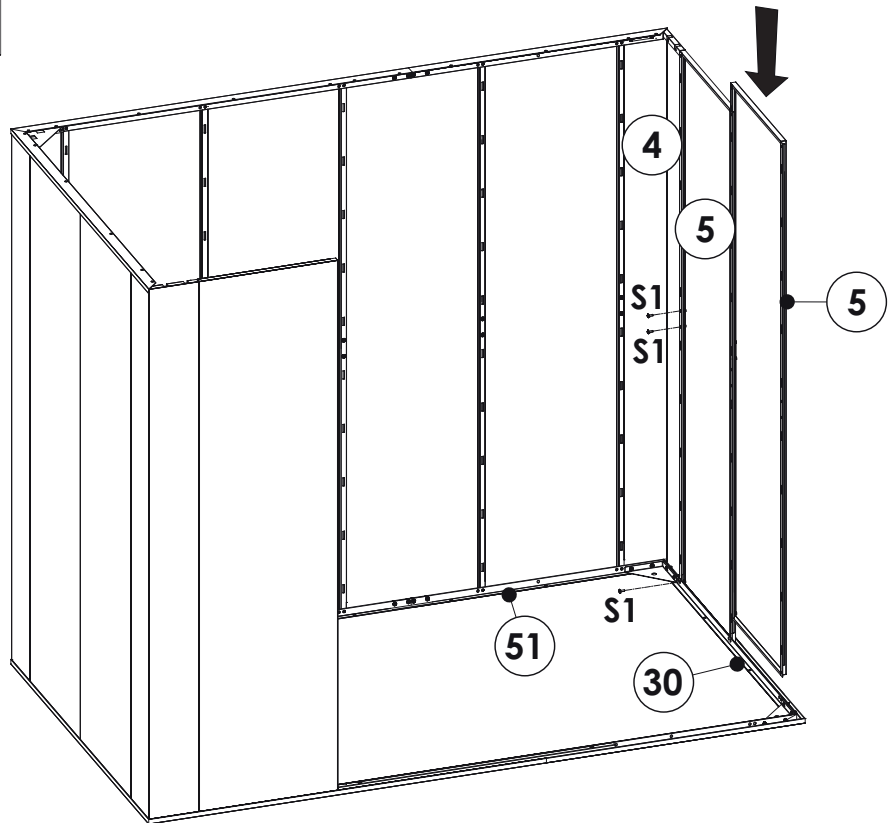
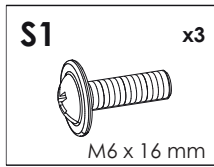

25

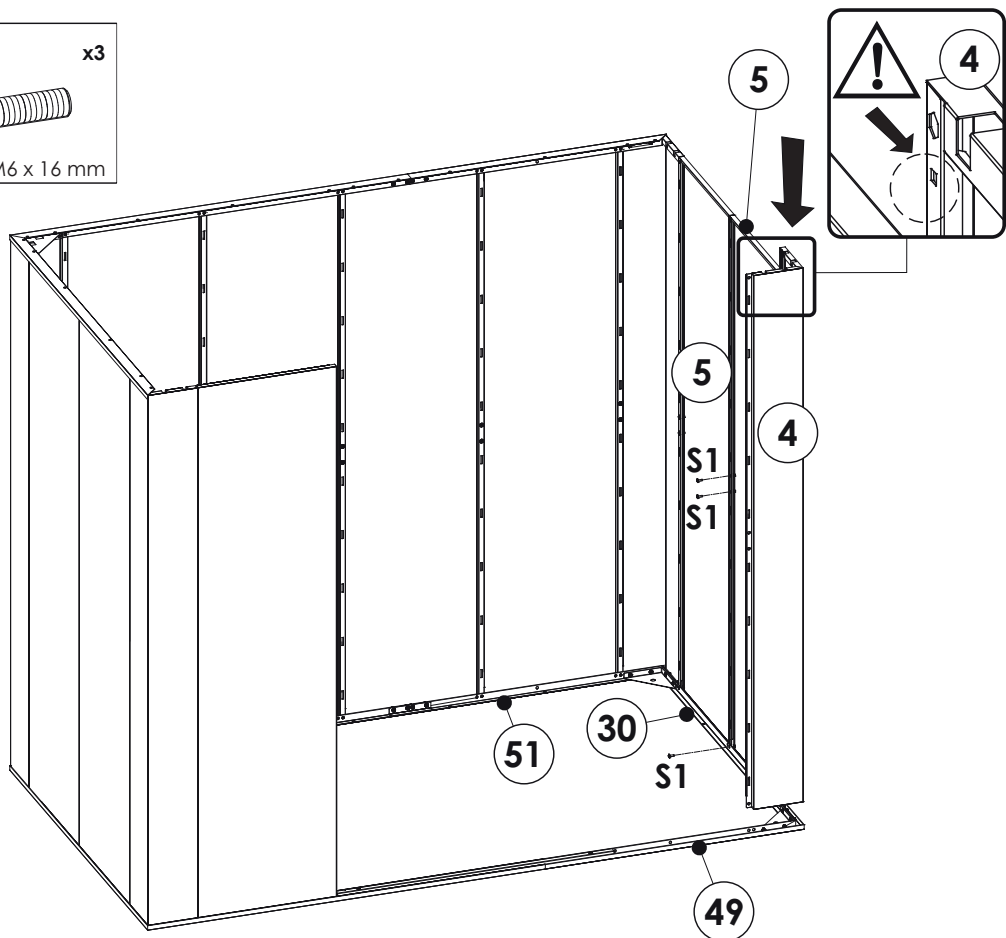
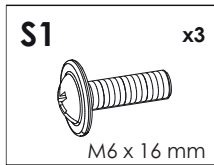

Installation

26

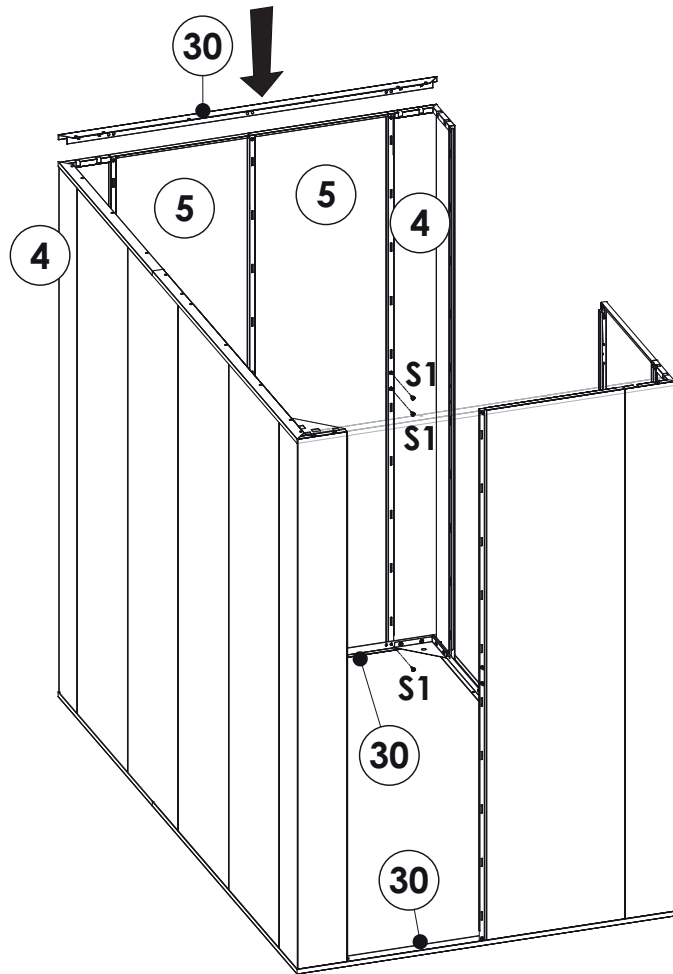
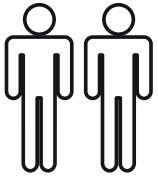
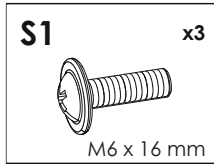

27

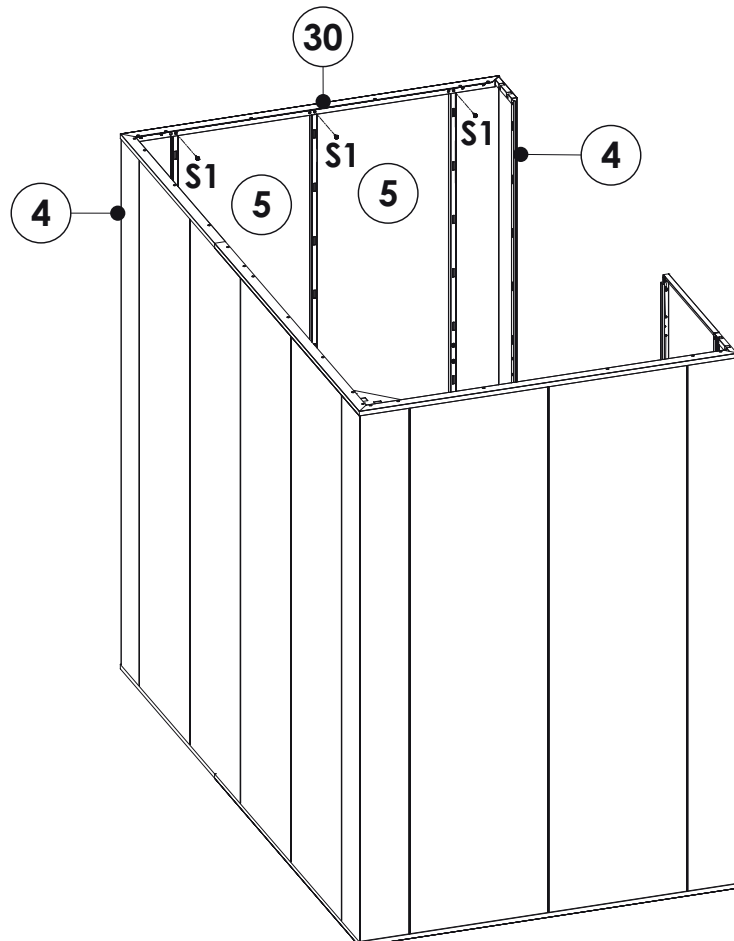
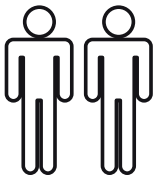
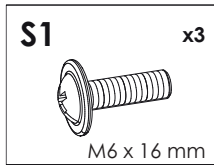

Installation

28

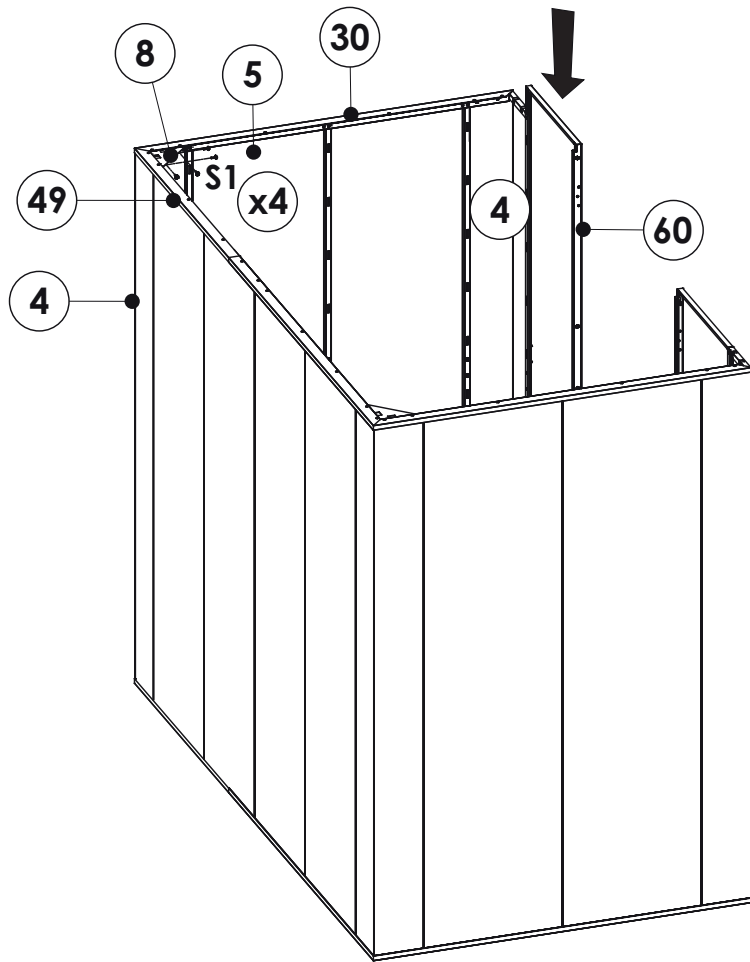
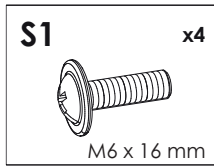

29

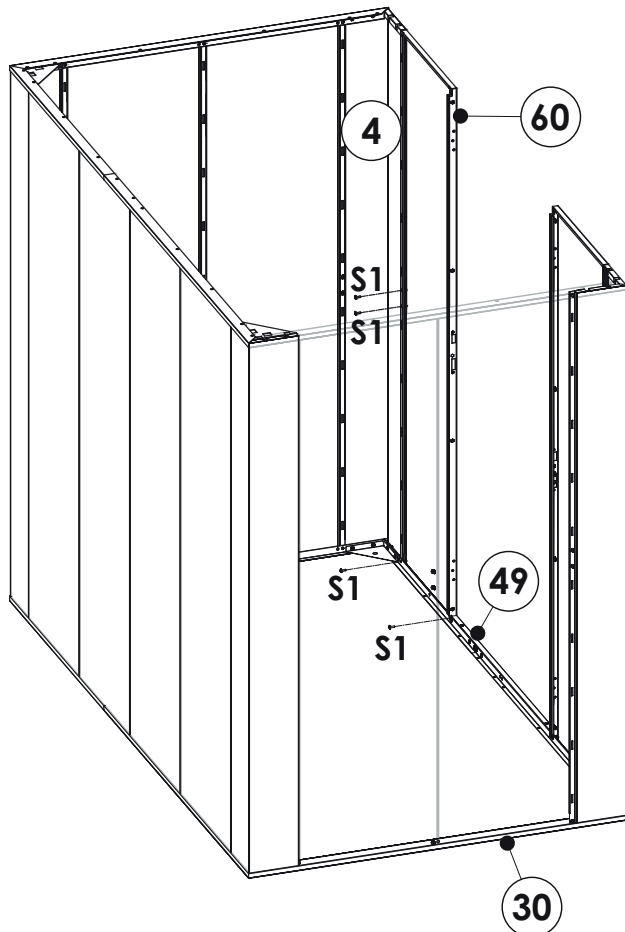
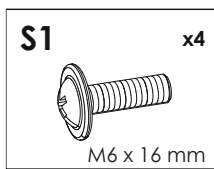

Installation

30

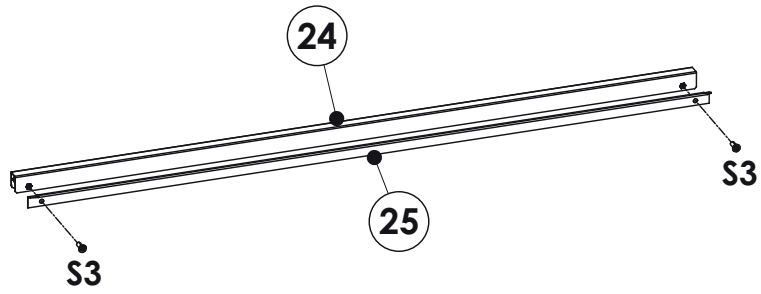

31

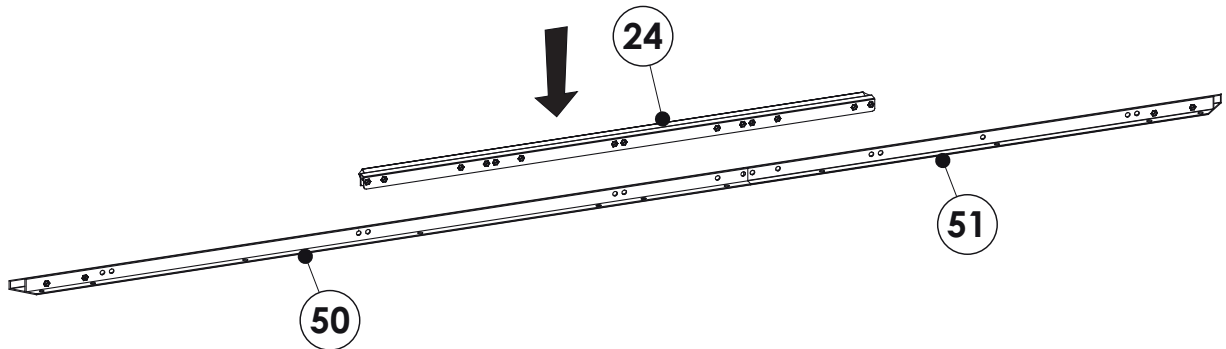

32

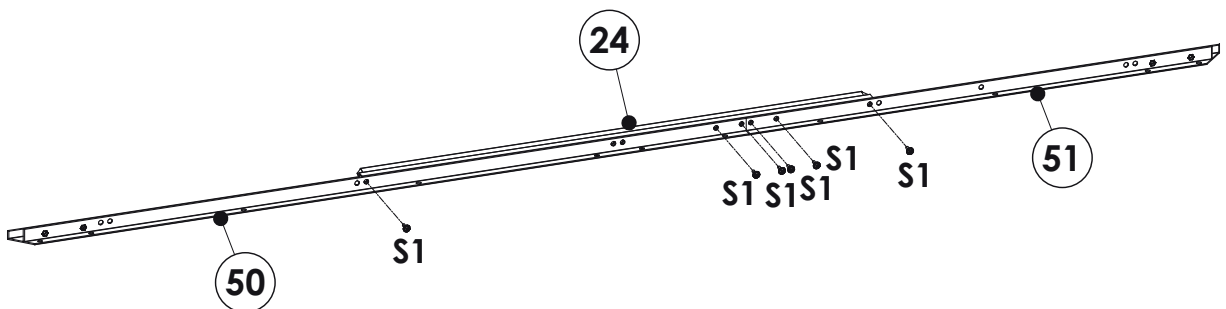
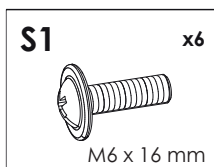

Installation

33

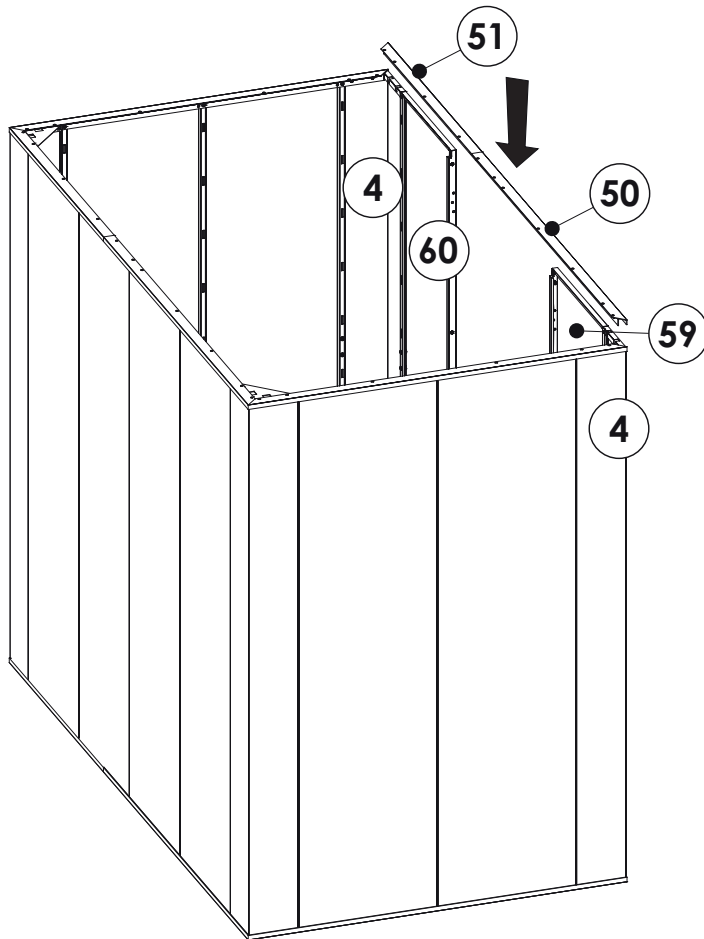

34

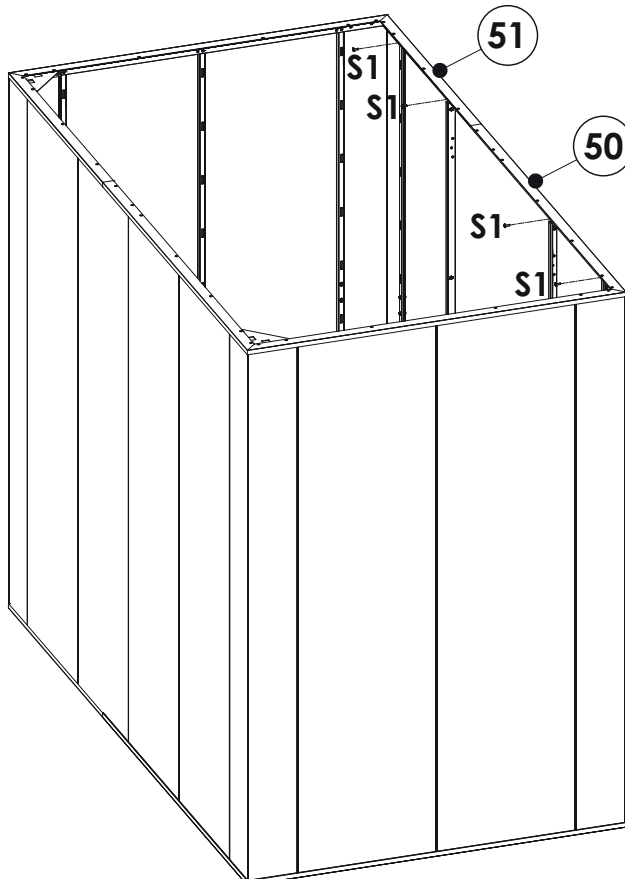
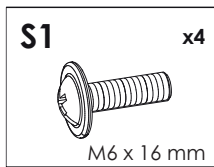

Installation

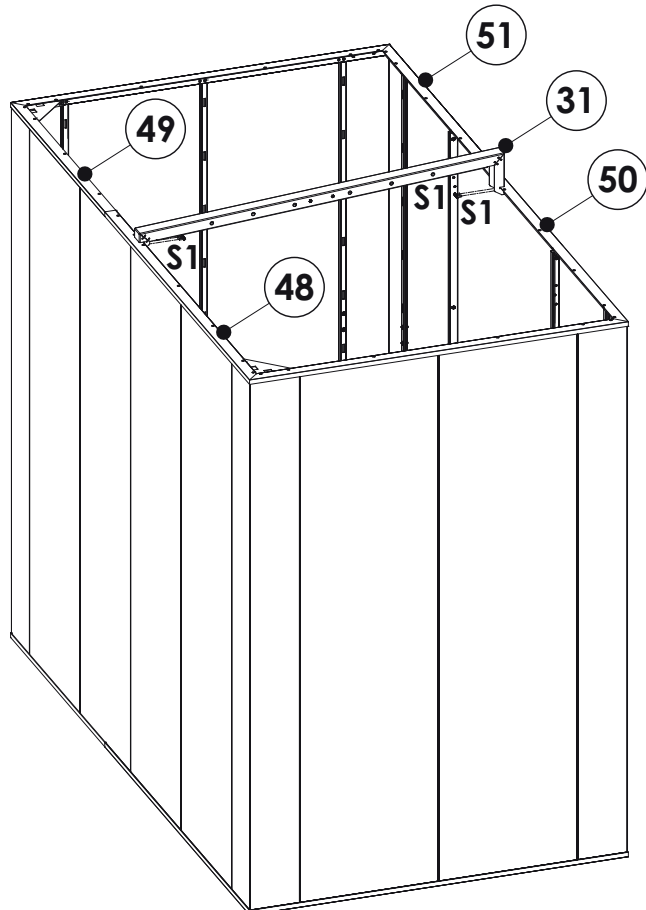
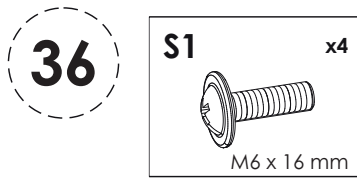
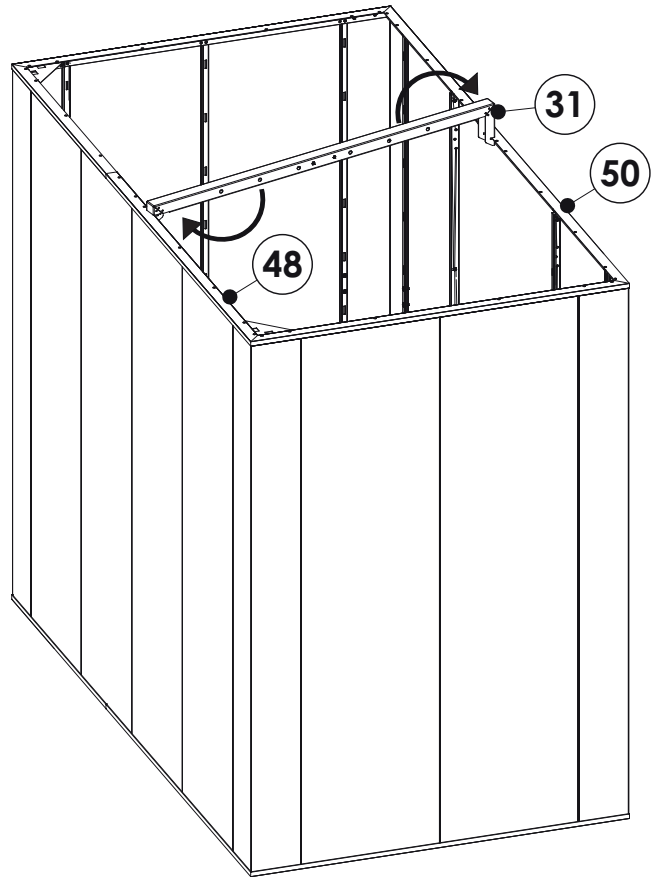
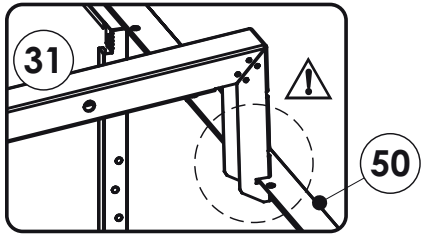
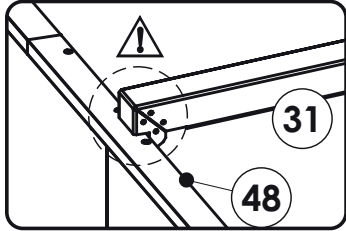

Installation

37

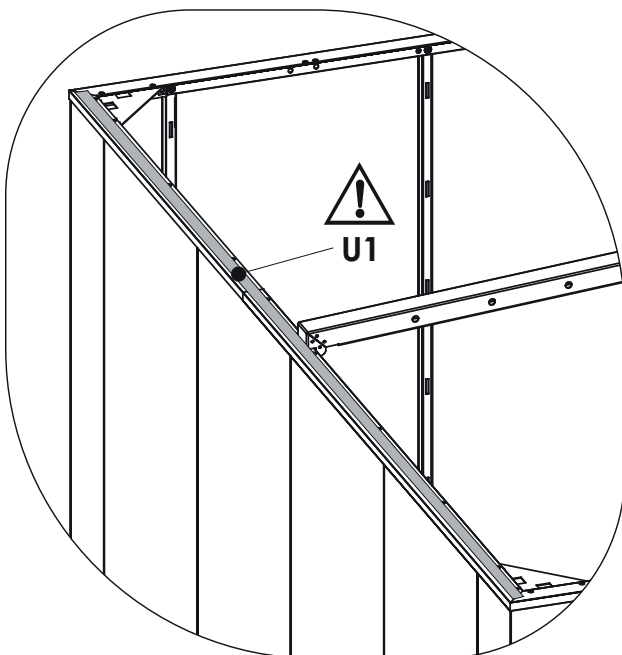
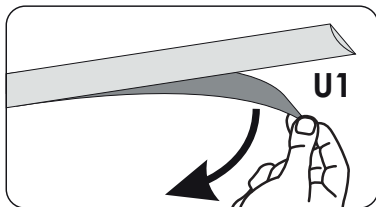
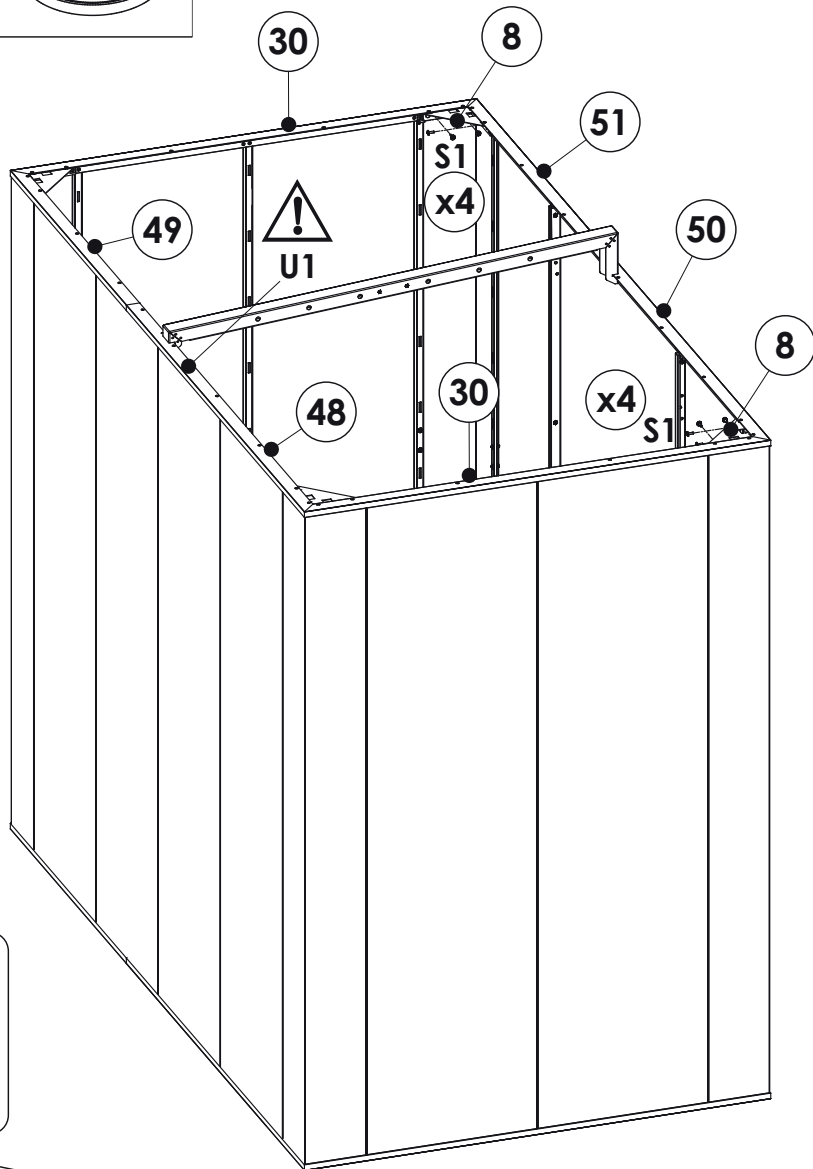
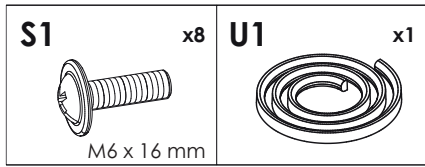

Installation

38

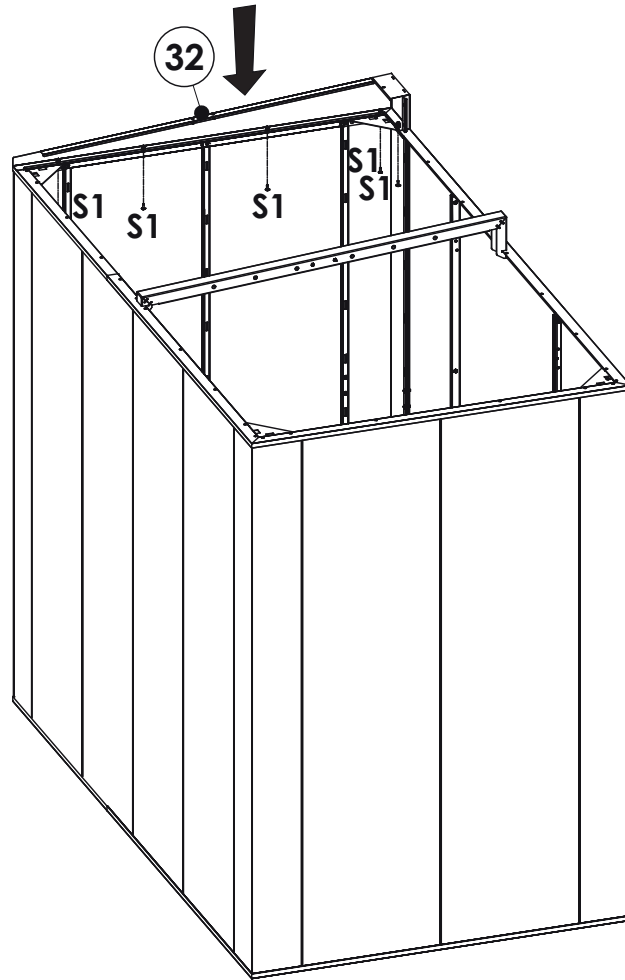
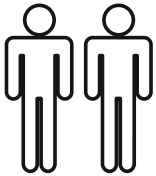
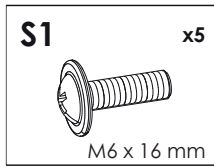

39

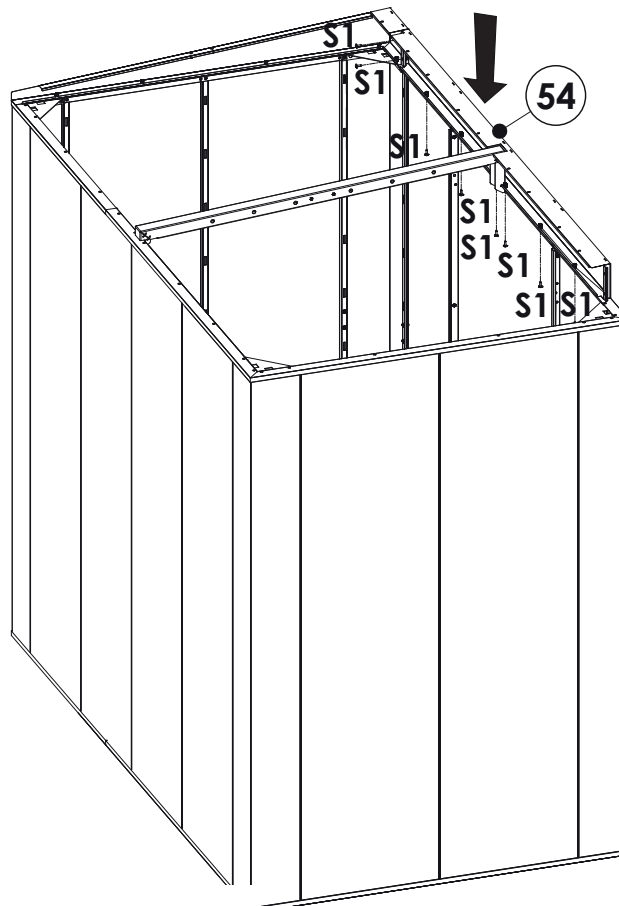
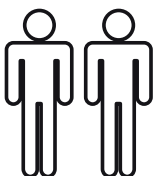
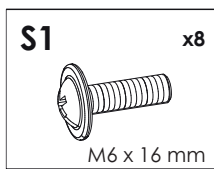

Installation

40

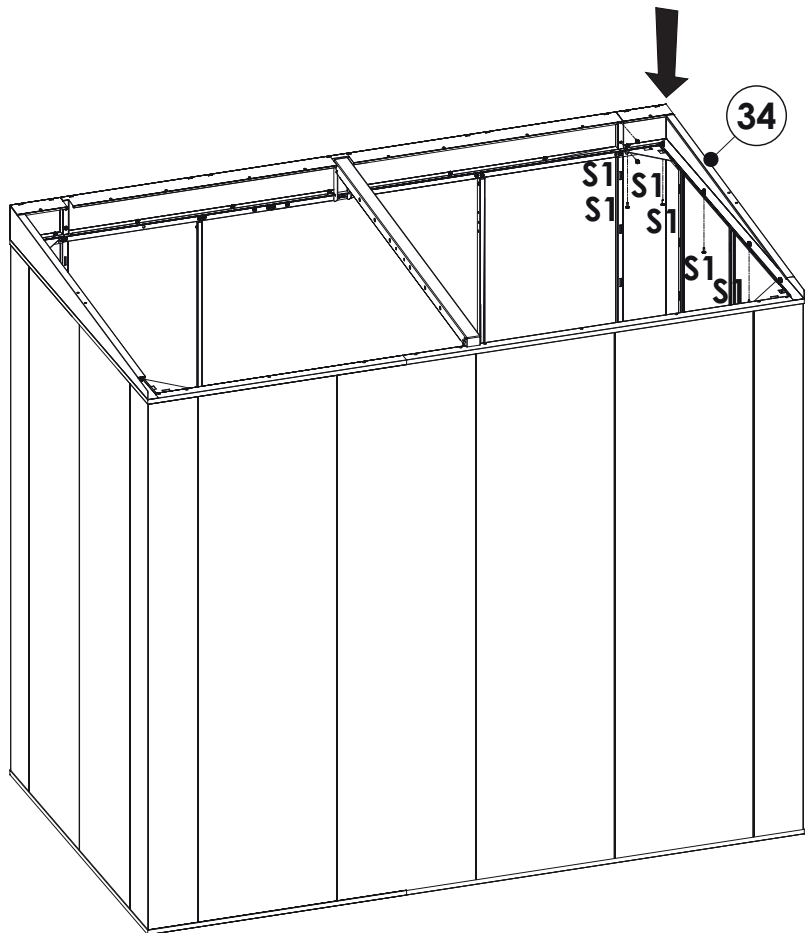
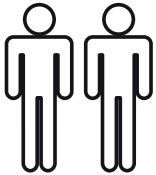
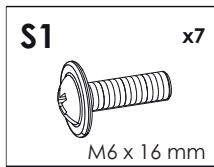

41

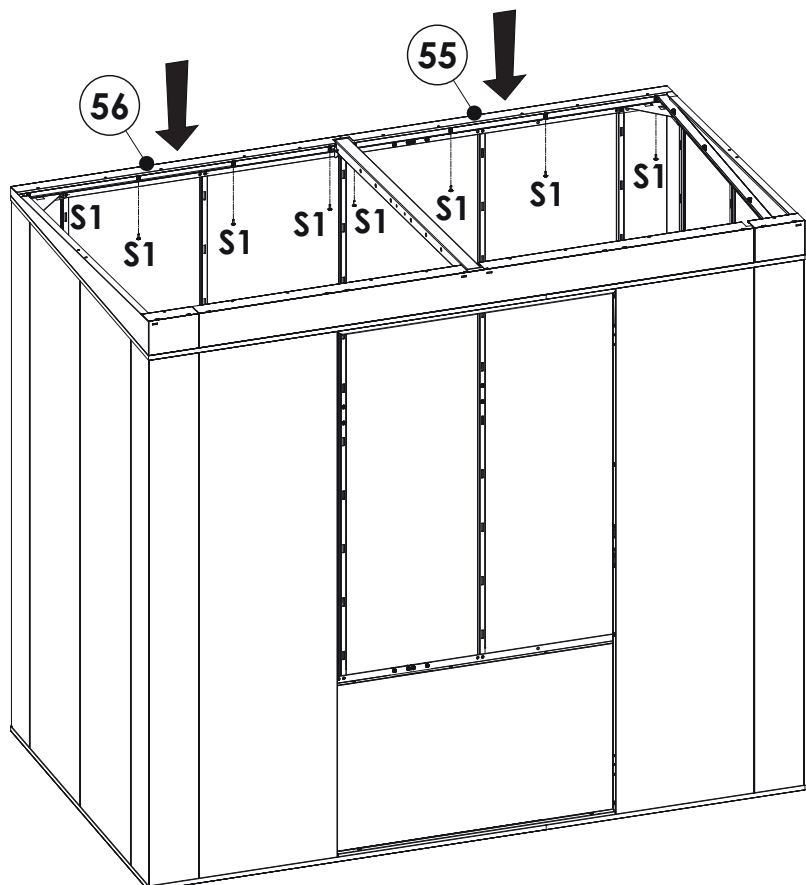
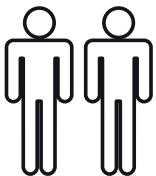
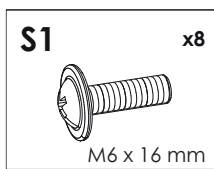

Installation

42

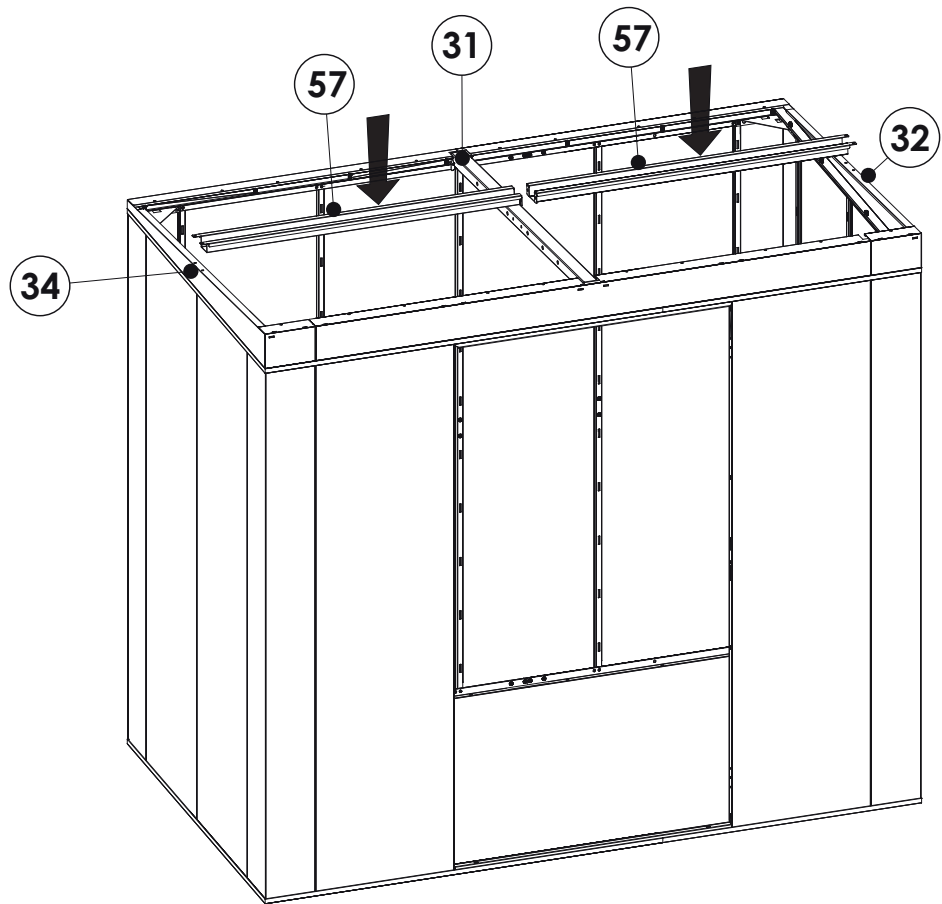
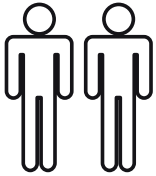

43

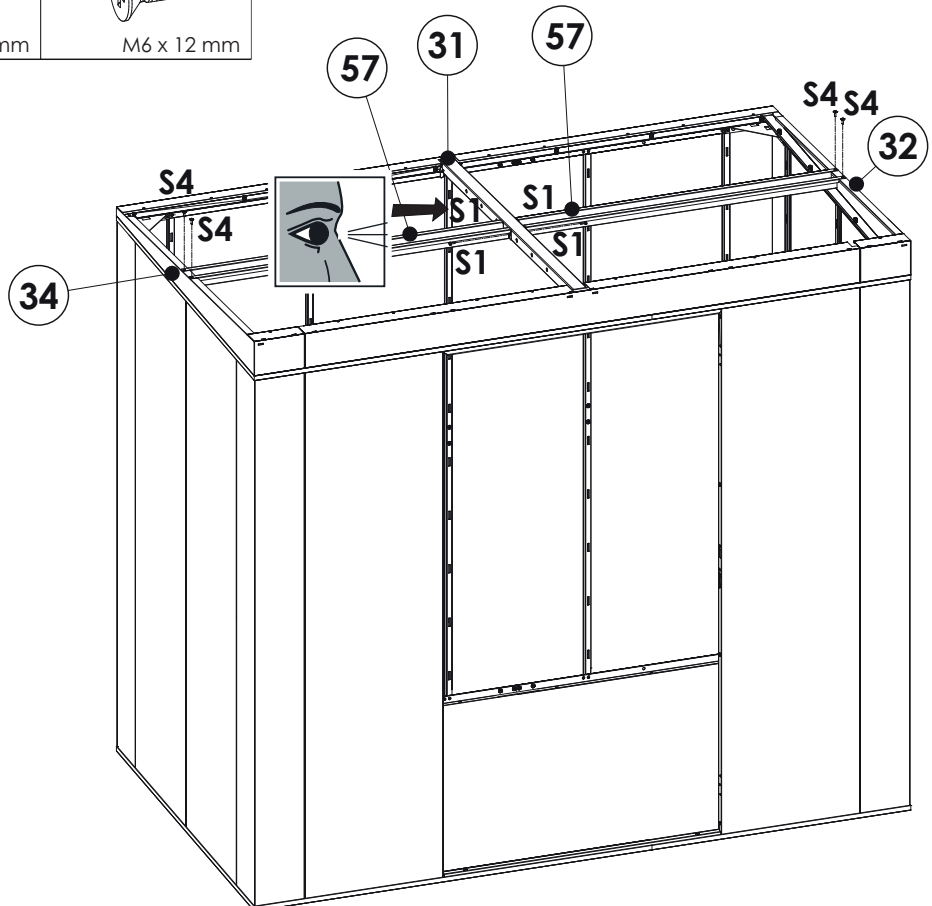
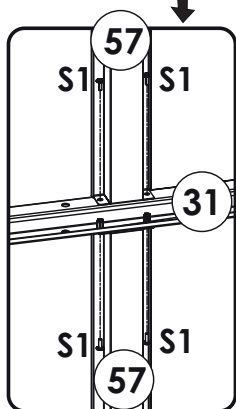
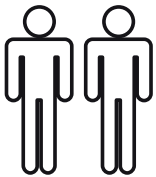
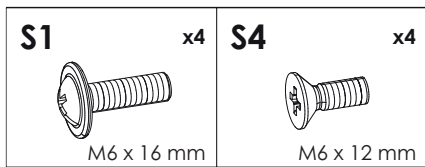

Installation

44

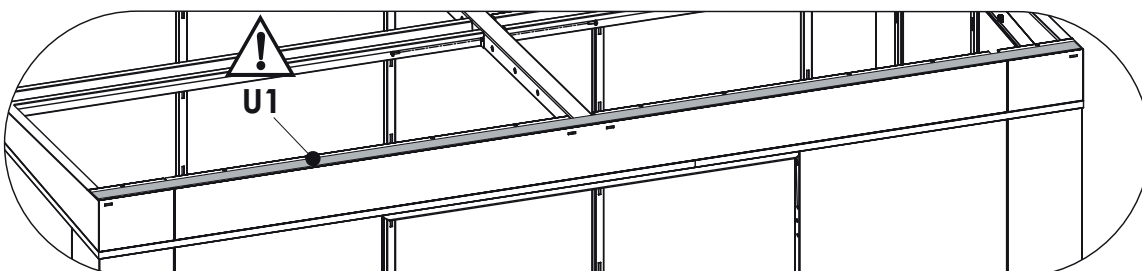
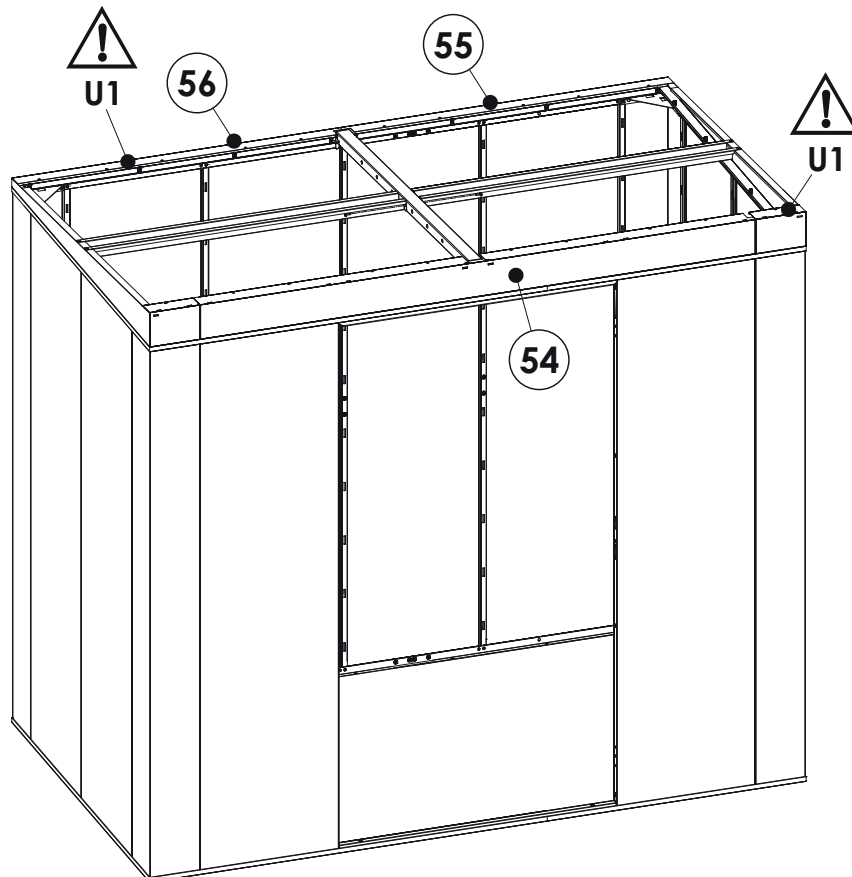
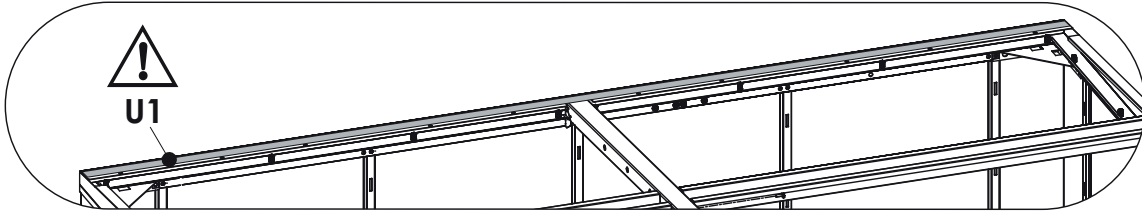
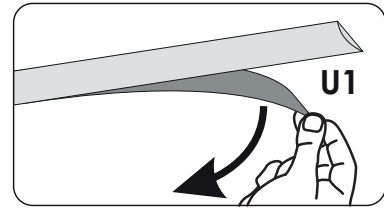
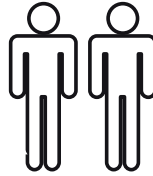
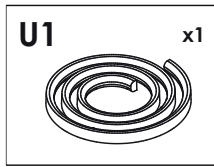

Installation

44

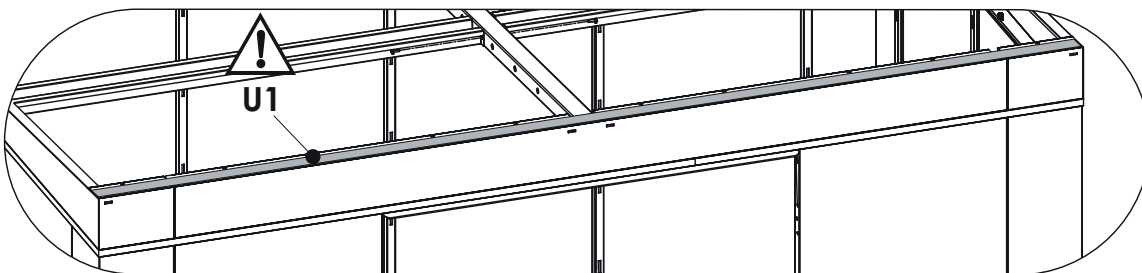
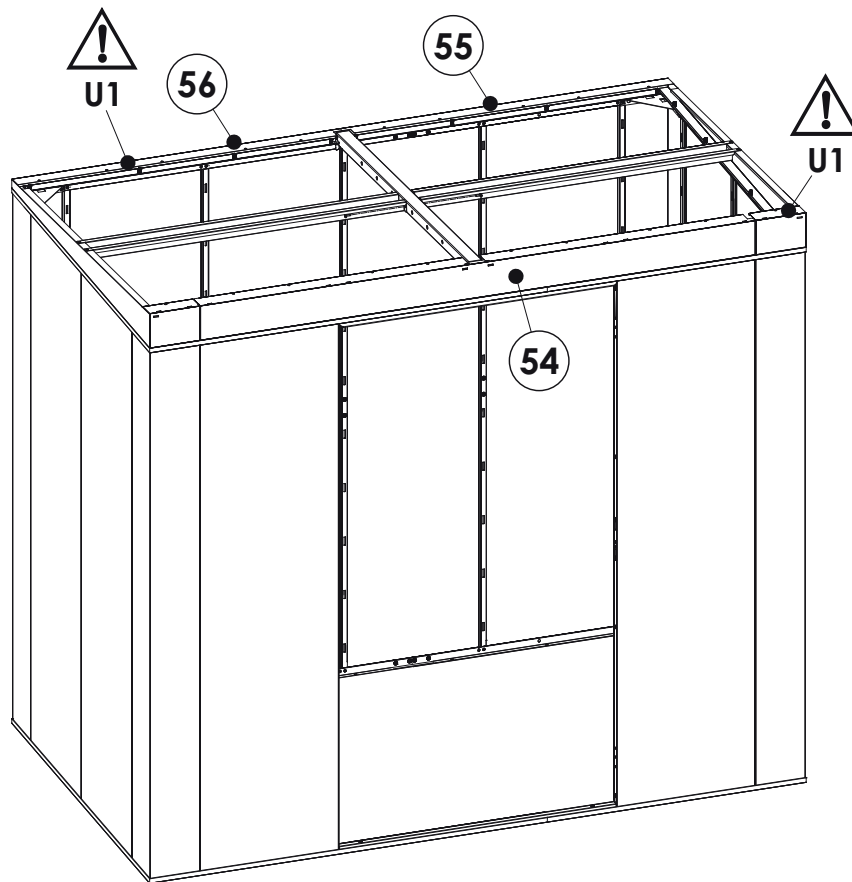
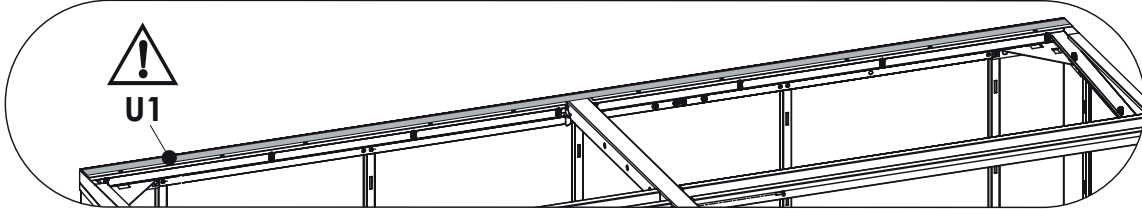
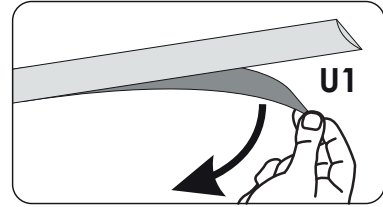
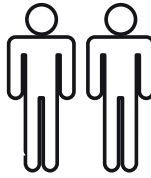
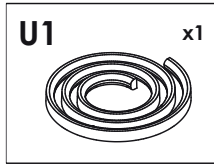

Installation

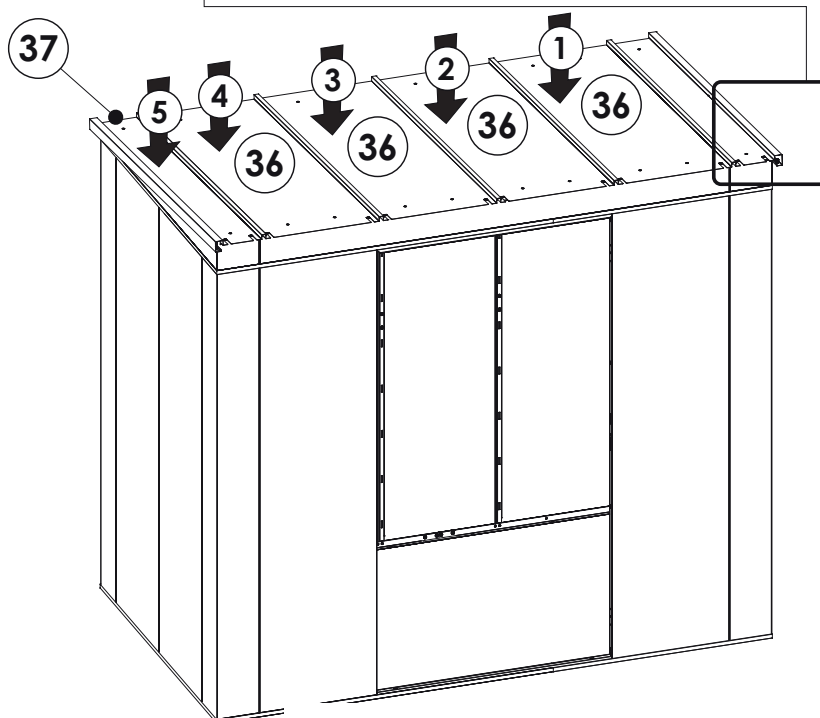
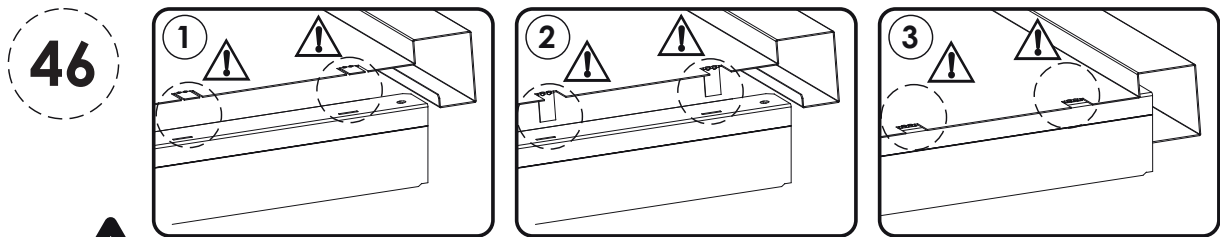
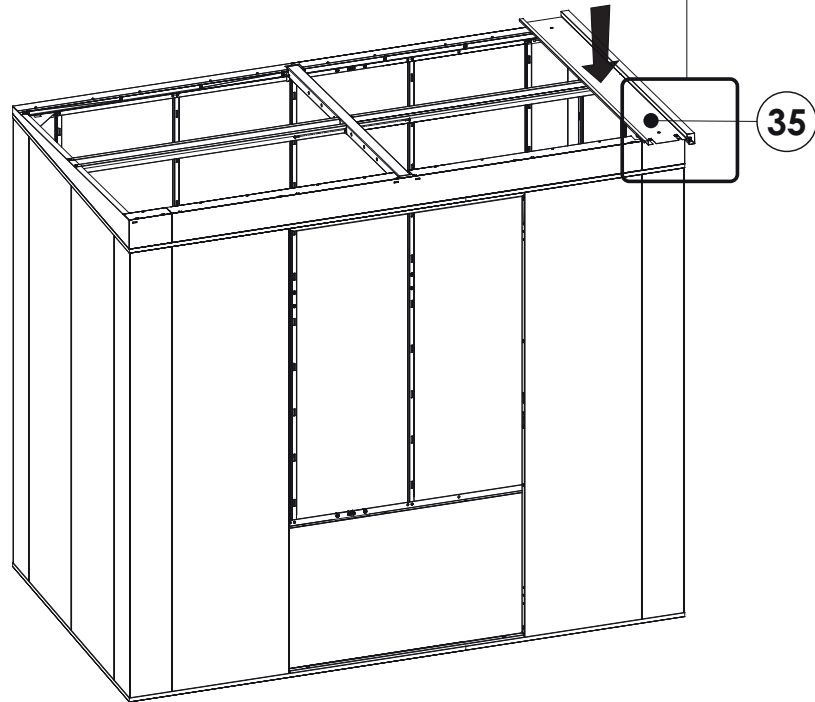
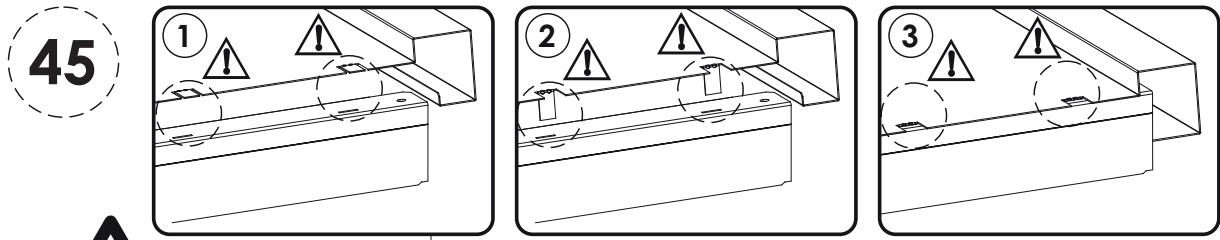

Installation

47

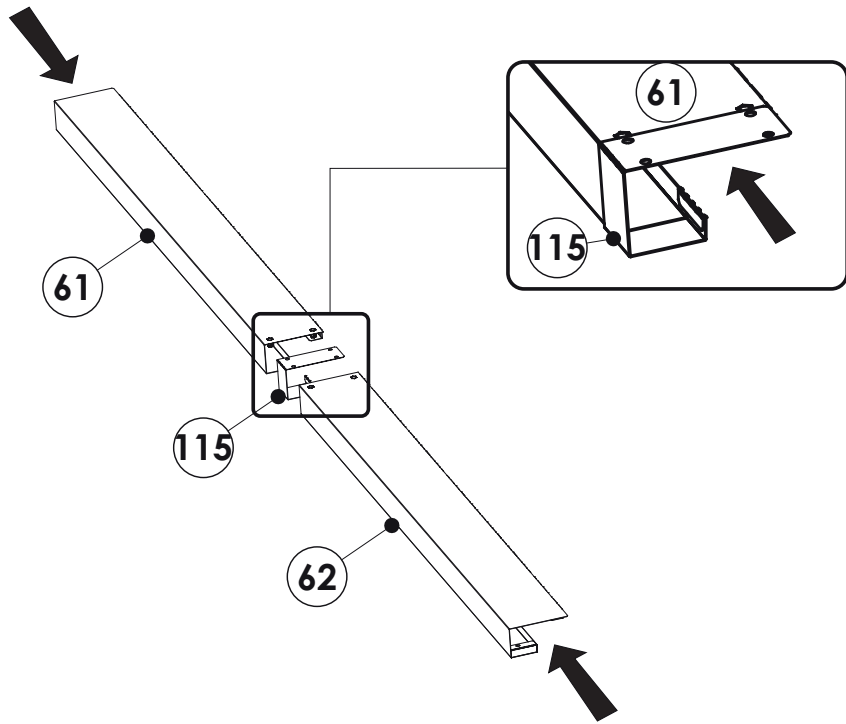

48

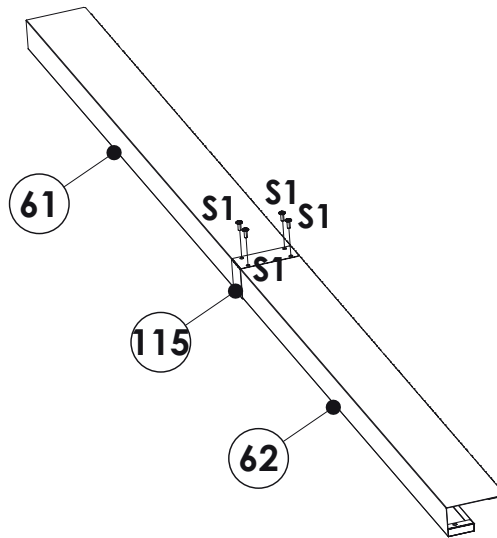
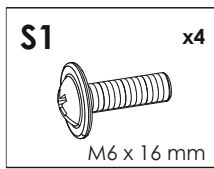

49

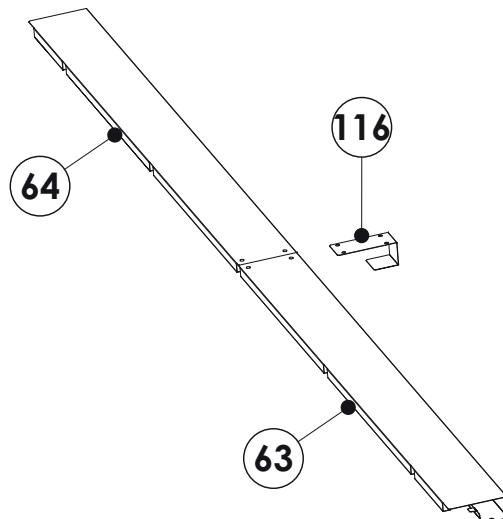

Installation

50

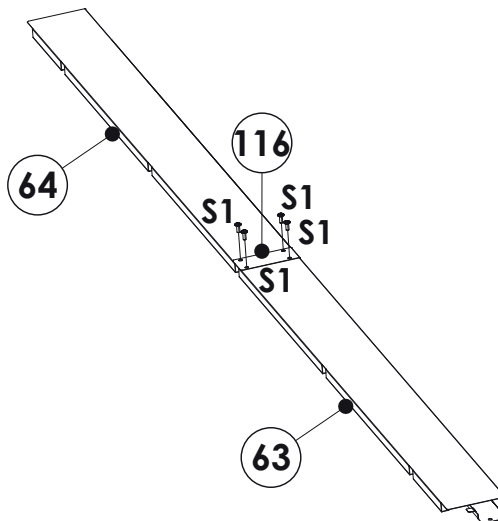
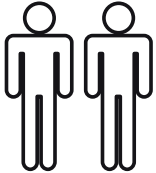
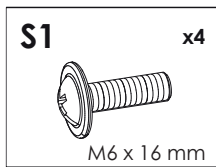

51

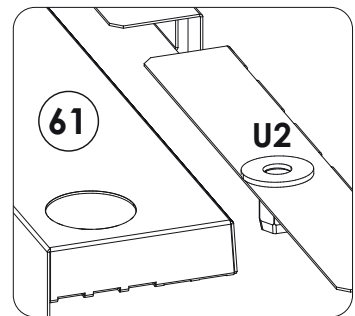
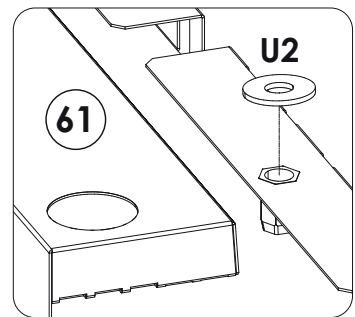
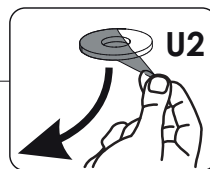
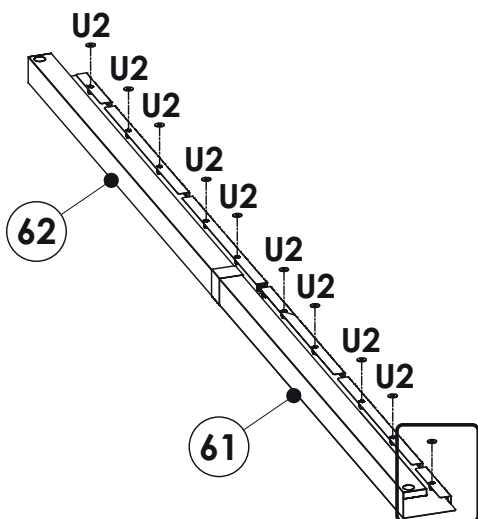
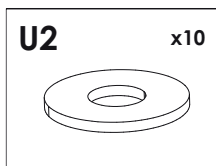

52

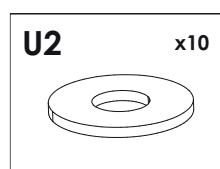
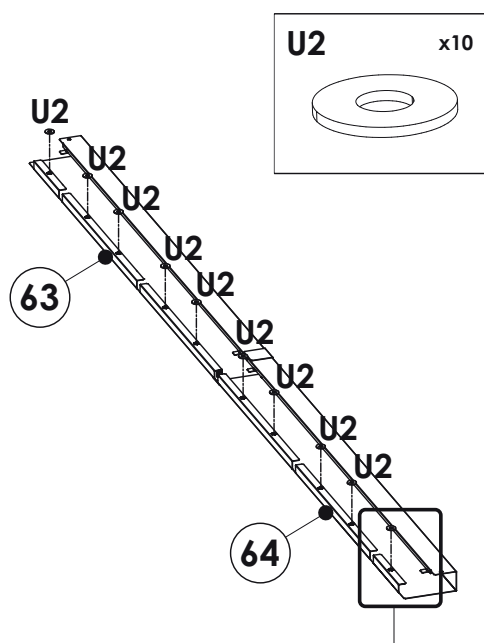
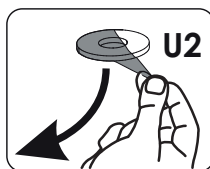
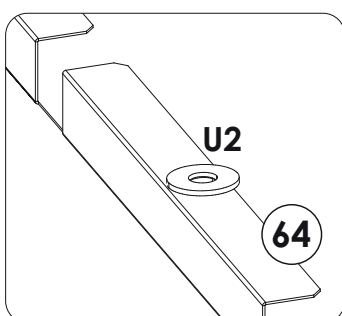
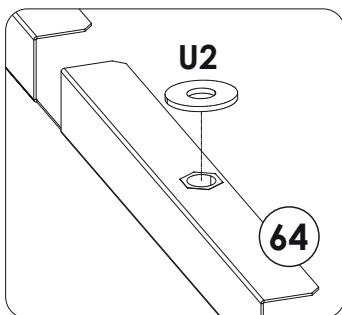

Installation

53

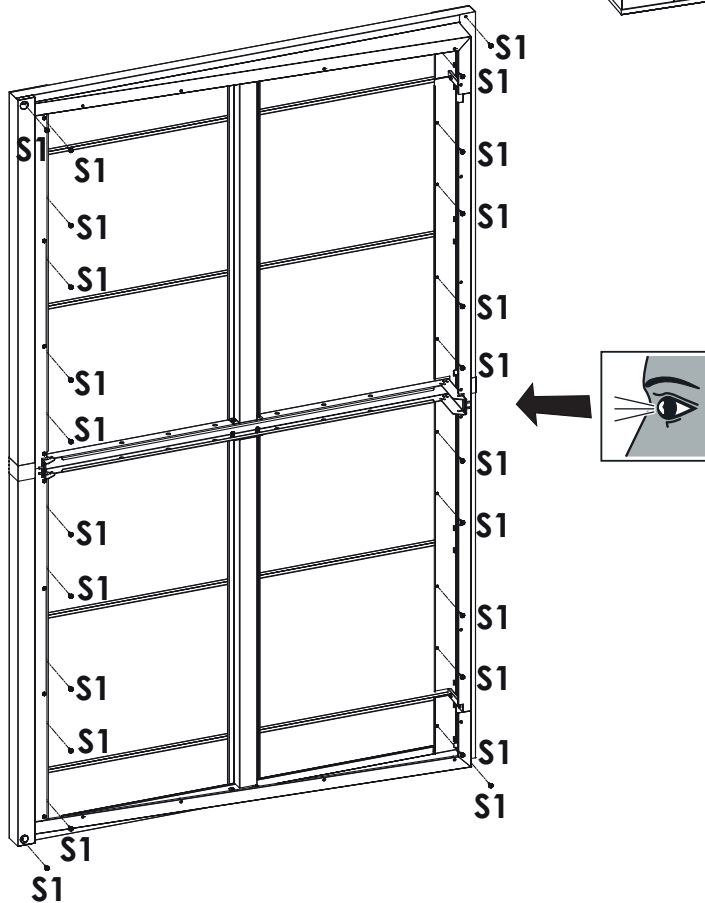
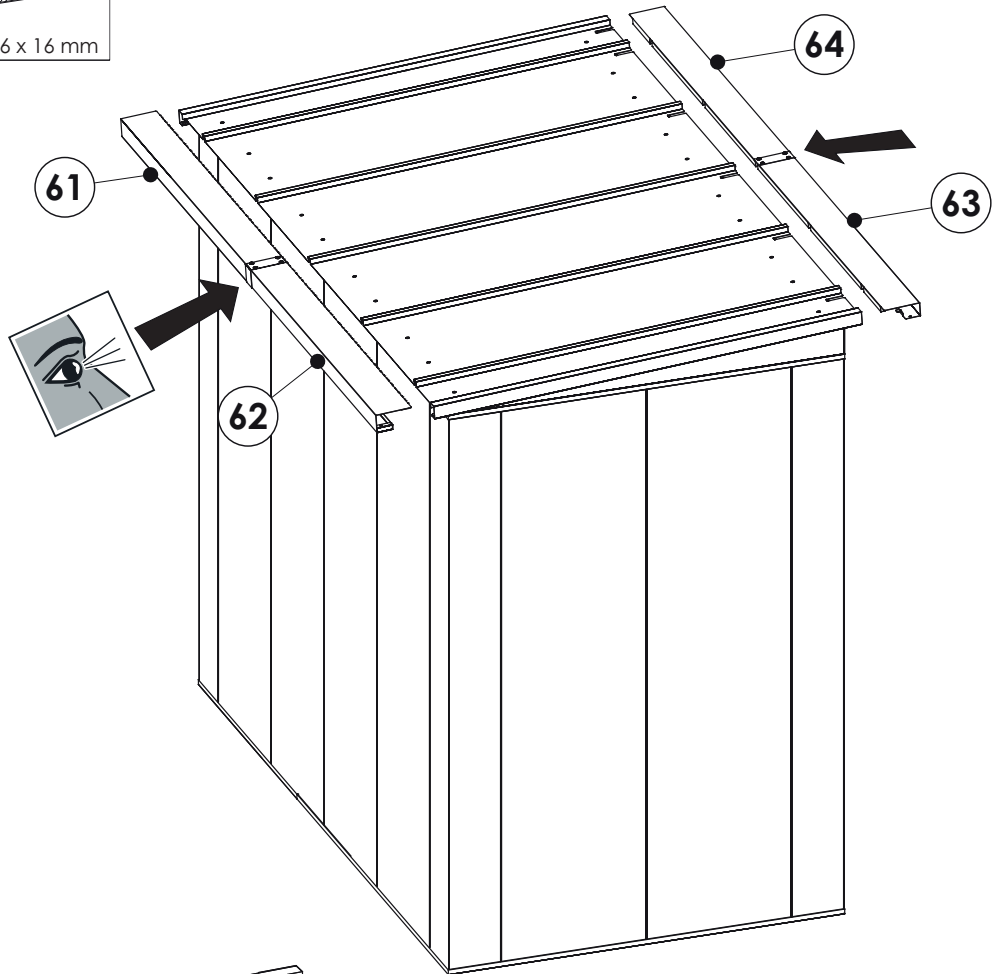
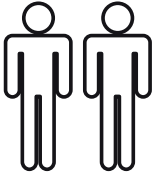
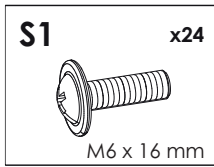

Installation

54

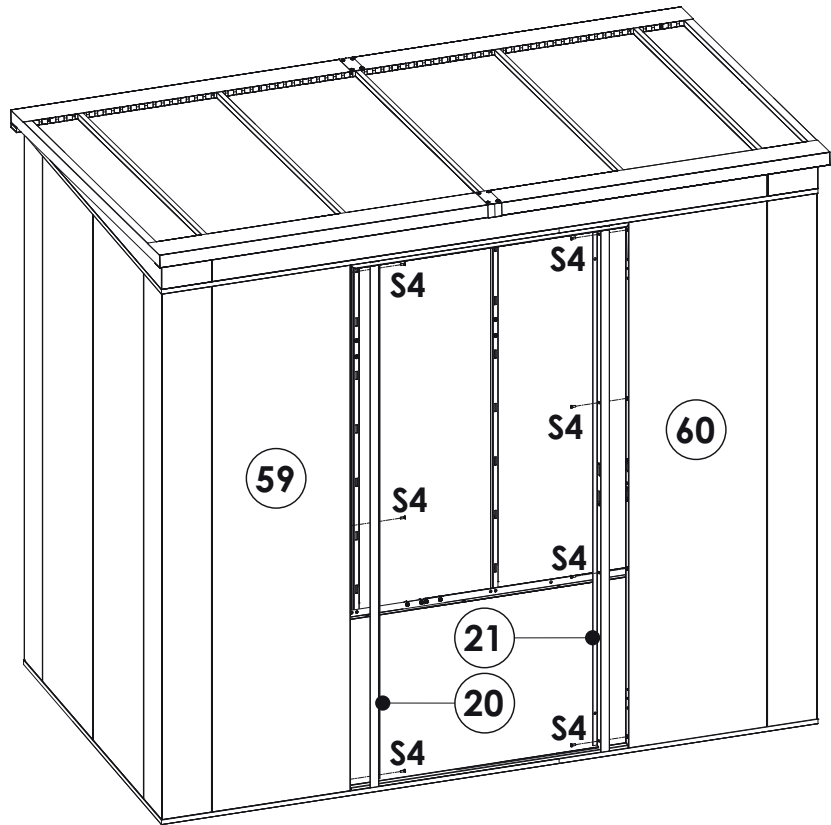
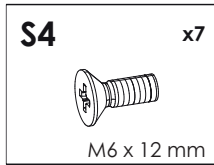

55

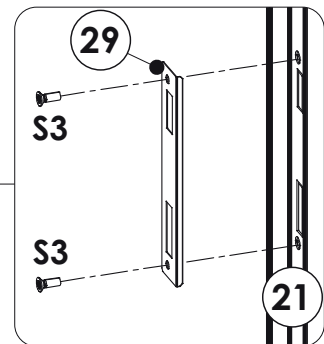
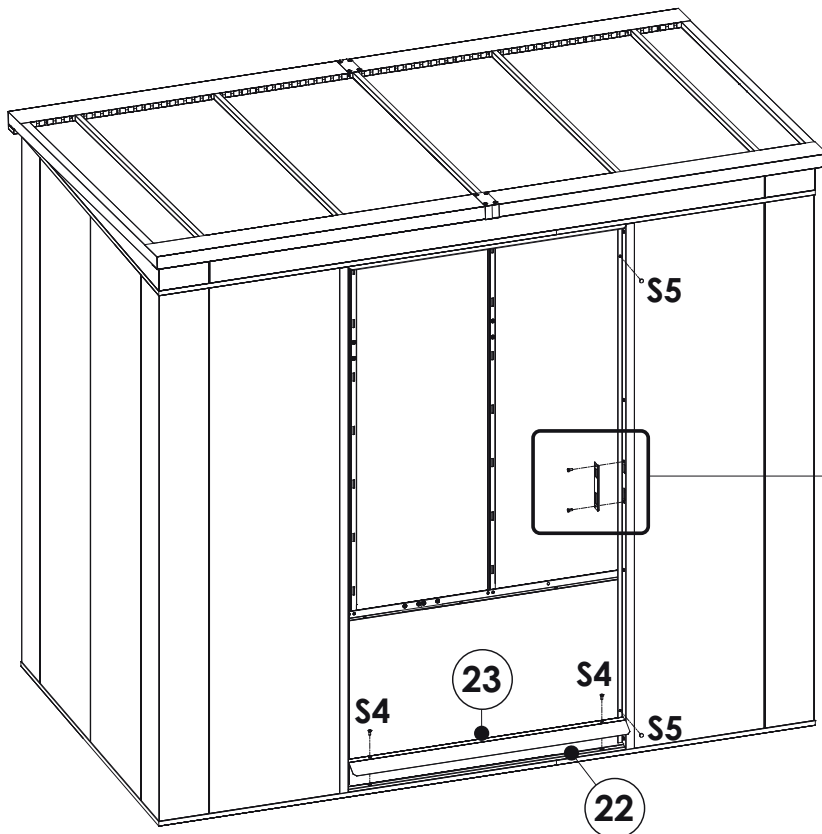
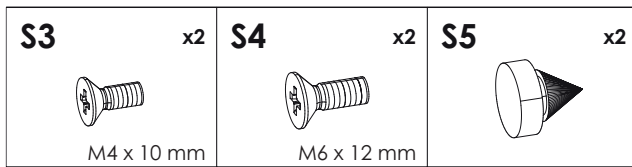

Installation

56

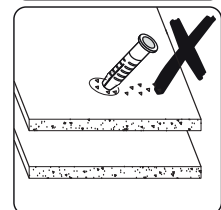
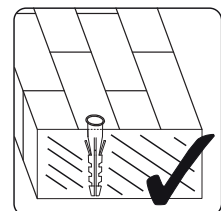
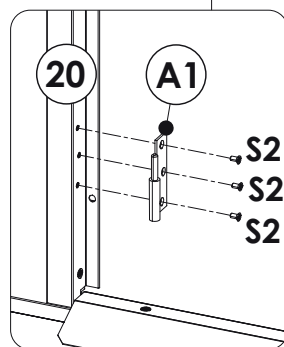
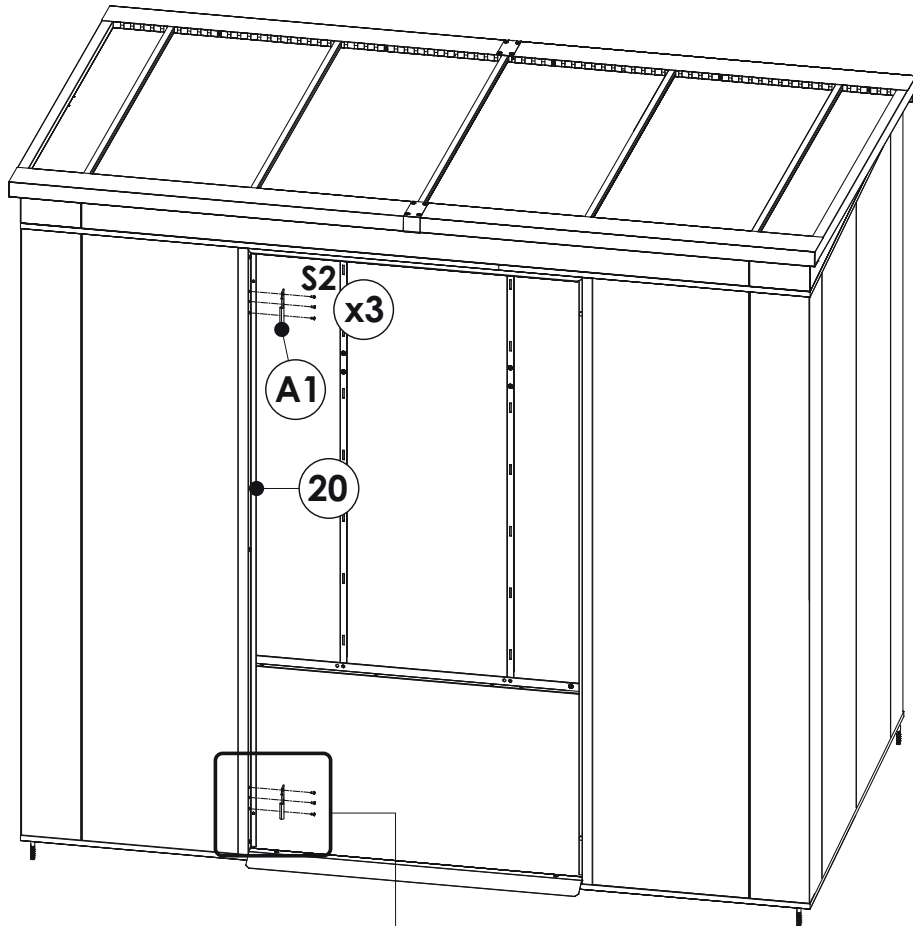
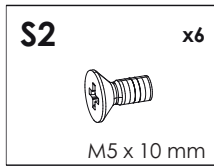

Installation

57

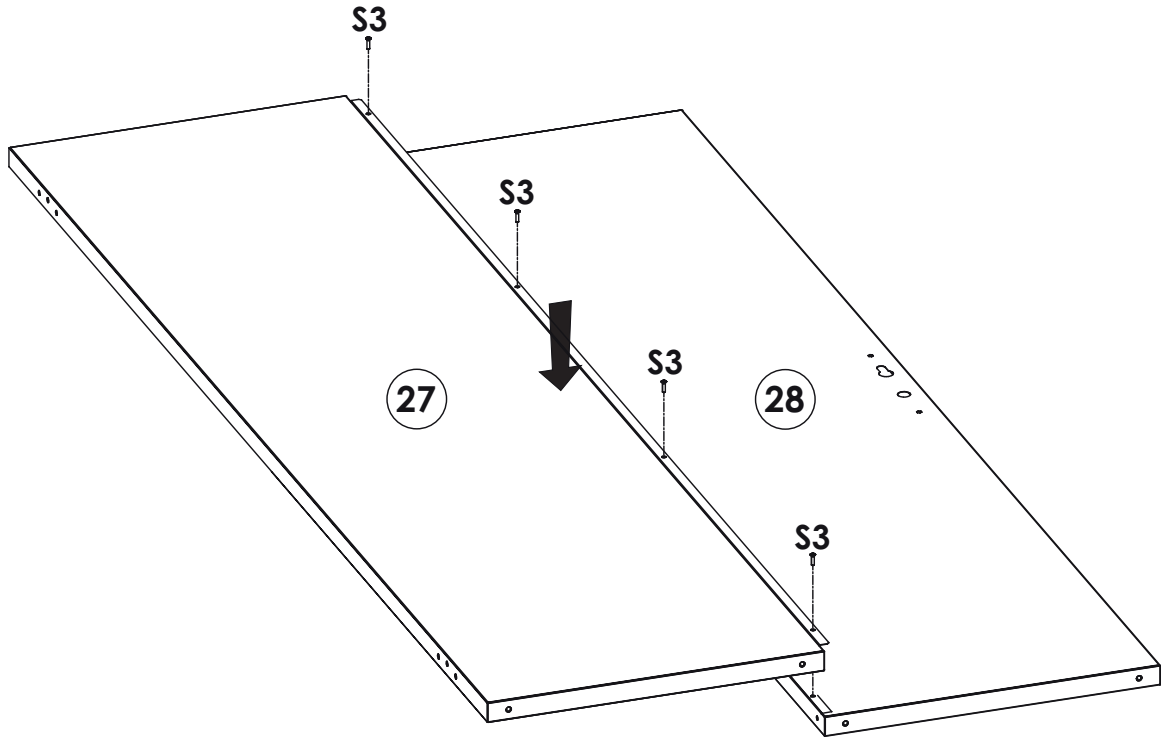
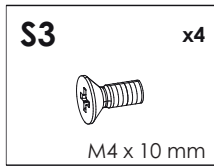

58

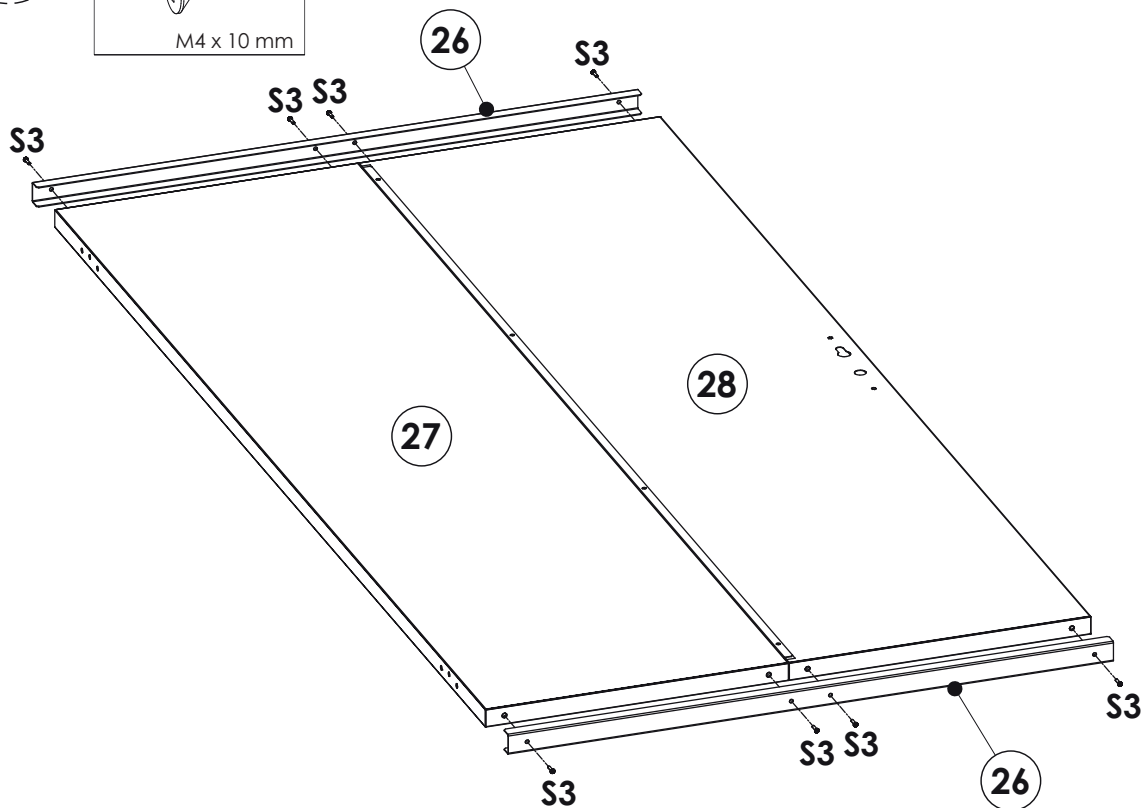
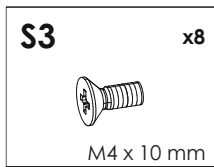

Installation

59

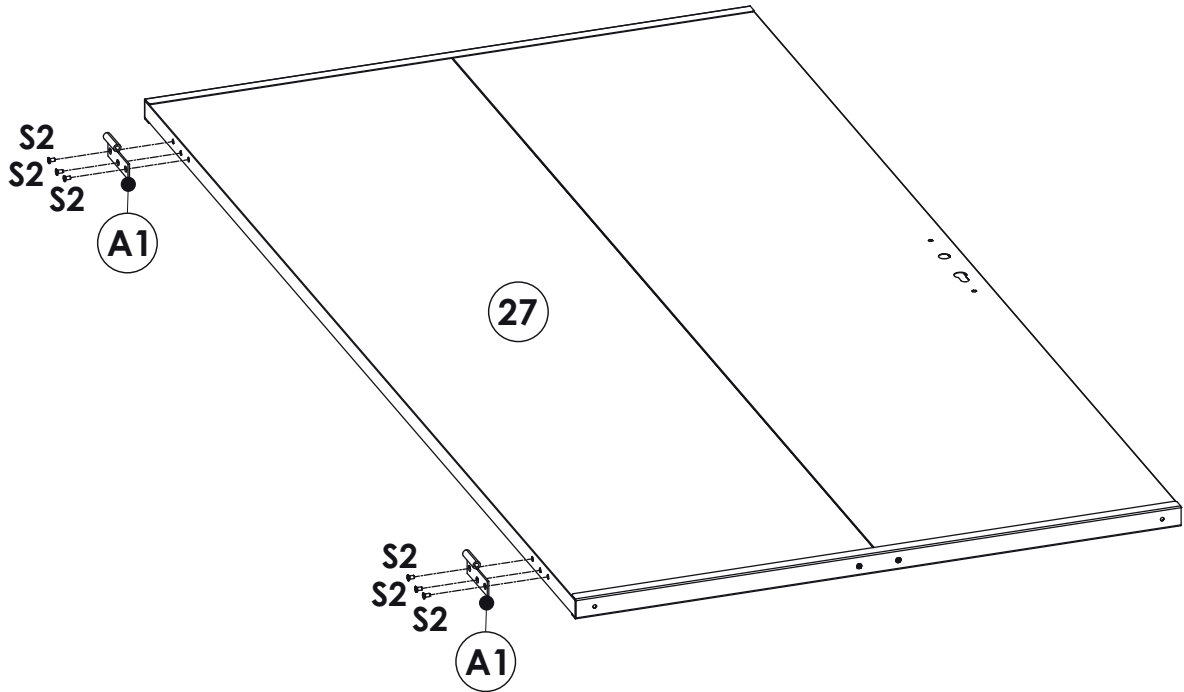
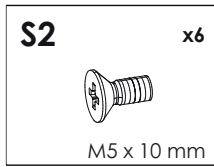

60

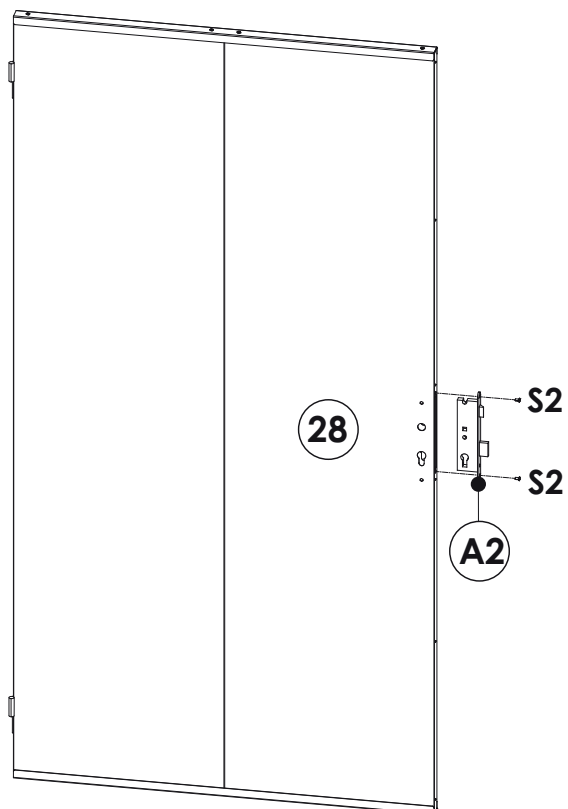
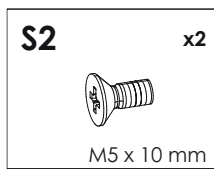

Installation

61

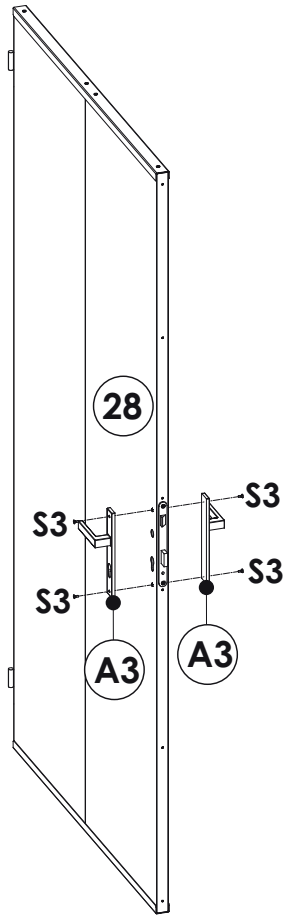
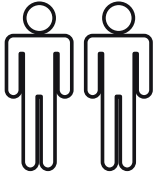
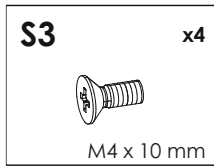

62

